

RAGOTZKY+GATJE

Holtener Strasse 288, 24106 Kiel | mail@ragotzkygaetje.de | 0431-389080
ragotzkygaetje.de | shop.ragotzkygaetje.de | spannsysteme-shop.de

HANS TREIBER

Gutenbergstrasse 19, 24558 Henstedt-Ulzburg | 04193-77943
mail@hanstreiber.de | shop.hanstreiber.de | fraeser-shop.de



HOMGE

Machine Tool Accessories



www.homge.com.tw



HOMGE

Quality engineering equipment
enhanced by continual research
and development for long
durability, high accuracy
and efficient operation

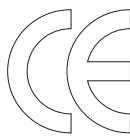

Established in 1978

CONTENTS

- 03 **Five-Axis Adjustable Self-Centering Vise**
- 04 **ASC-S Series Vise**
- 10 **ASC-M Series Vise**
- 14 **ASC-K Series Vise**
- 16 **Five-Axis Compact Multi-Power Vise**
- 19 **Five-Axis Compact Vise**
- 20 **CNC Compact Multi-Power Super Vise**
- 22 **Zero Point Quick Change Devices**
- 23 **Base Plate**
 - 24 Rectangular Plate
 - 26 Round Plate
 - 29 Grid Plate
- 30 **Adapter Plate 52/96**
- 32 **Adapter Plate for 3-Jaw Chuck**
- 34 **Column**
 - 35 Twin Base
- 36 **Master Gauging Pallet**
- 38 **Riser Block**
 - 39 Round Aluminum Riser
 - 40 Rectangular Riser
- 42 **Multi Plate**
 - 43 2-Fold Grid Plate
 - 44 4-Fold Grid Plate
 - 45 Side-Mounted Plate
- 46 **Clamping Bridge**
- 48 **Tombstone**
 - 49 3-Faced / 4-Faced Tombstone
- 50 **3-Faced Pyramid**
- 51 **Combo Plate / Raiser**
- 52 **Top Clamping**
- 53 **Optional Accessories**
- 54 **Stamping Unit**
- 56 **Fast Actuation System**



FIVE-AXIS ADJUSTABLE SELF-CENTERING VISE

FIVE-AXIS ADJUSTABLE SELF-CENTERING VISE



FIVE-AXIS ADJUSTABLE SELF-CENTERING VISE

4

FIVE-AXIS ADJUSTABLE SELF-CENTERING VISE / ASC-S SERIES

Model: ASC-77x102S, 77x130S, 77x170S, 77x210S
ASC-127x160S, 127x210S, 127x260S, ASC-127x310S, 127x360S



- Patented stud bolt seat design can efficiently calibrate the clamping center.
- It is recommended to operate with a Master Plate on a five-axis machine.
- Compatible with Robotic Arms.



ASGS Series

STANDARD ACCESSORIES:

- 4 pcs of Clamp
- 1 pc of Wrench



<p>Users can calibrate the clamping center of vise by adjusting the screws on both ends.</p>	<p>Detachable jaws are made of High quality Tool Steel (SCM440) and gone through carburizing to achieve HRC55. Since both sides are fixed size and able to be used as a datum, users can reverse them to increase clamping range.</p>	<p>The vise's clamping force can achieve 1300KG, the repeatability positioning precision of its clamping center is within ±0.02mm.</p>	<p>The 45° dovetail structure with teeth on the upper jaw ensures the bottom of the workpiece to be firmly clamped.</p>	<p>Vise body is made of High quality Steel (S50C) and its slideways gone through high-frequency hardening to achieve HRC50, which makes the whole part durable.</p>
<p>1</p>	<p>2</p>	<p>3</p>	<p>4</p>	<p>5</p>



ASC-S Series

Model: ASC-77x102S, 77x130S, 77x170S, 77x210S
ASC-127x160S, 127x210S, 127x260S, 127x310S, 127x360S



ASC-77x102S

Size 107x77x70 mm

Weight (kg) 2.8

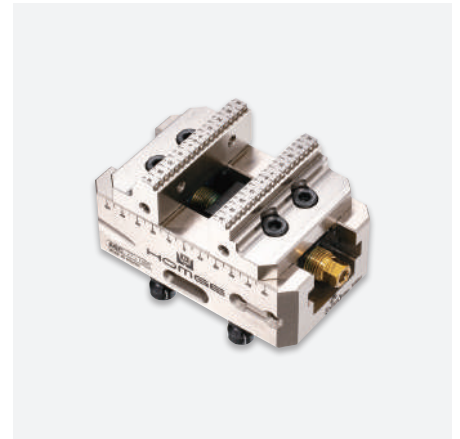

ASC-77x130S

Size 135x77x70 mm

Weight (kg) 3.5

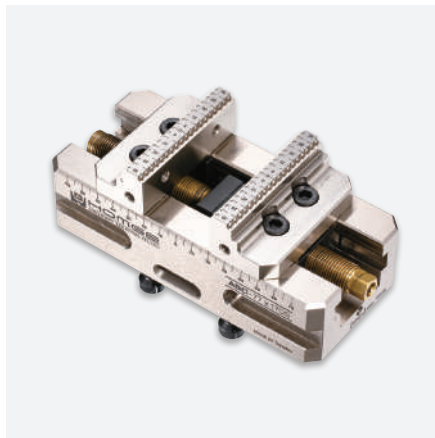

ASC-77x170S

Size 175x77x70 mm

Weight (kg) 4.2

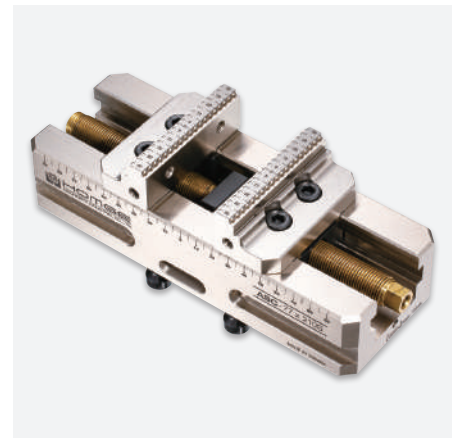

ASC-77x210S

Size 215x77x70 mm

Weight (kg) 4.9



ASC-127x160S

Size 165x127x87 mm

Weight (kg) 9



ASC-127x210S

Size 215x127x87 mm

Weight (kg) 11



ASC-127x260S

Size 265x127x87 mm

Weight (kg) 13



ASC-127x310S

Size 315x127x87 mm

Weight (kg) 15



ASC-127x360S

Size 365x127x87 mm

Weight (kg) 17

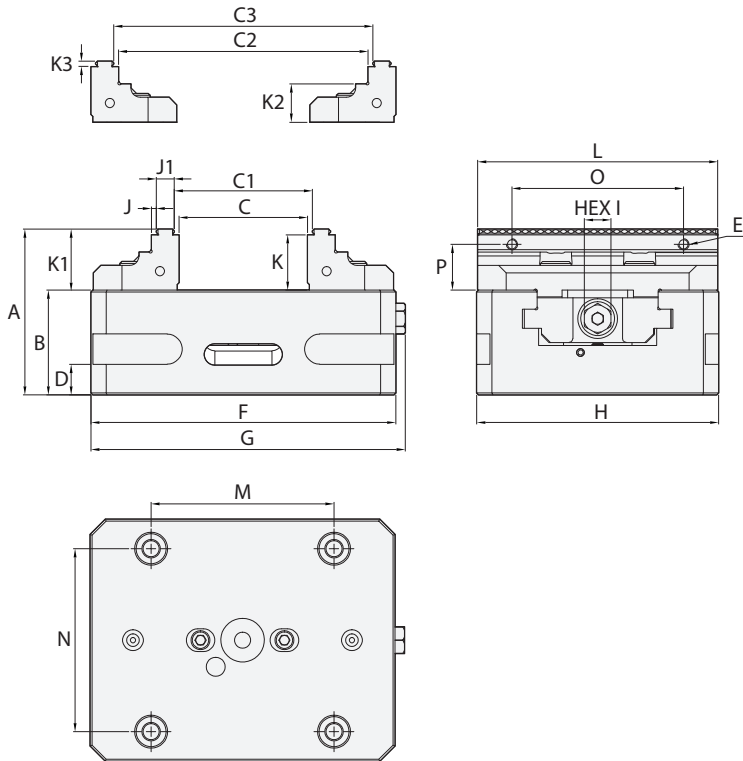

Narrow Version :

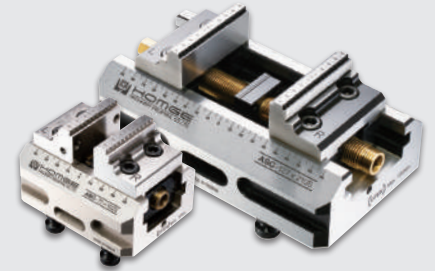

The Narrow Version of our Vise Body and Jaw Sets is a solution designed specifically to manage interference problems. All of our ASC-S series models are readily available.

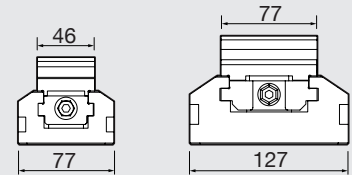

SPECIFICATIONS (Material: Vise body S50C, Hardness: HRC 50/ Detachable Jaws SCM440, Hardness: HRC 55)

Unit: mm

Model	A	B	C	C1	C2	C3	D	E	F	G	H	I	J	J1
ASC-77X102S	70	43	28	32	75	80	10	M6	102	107	77	12	2	9.5
ASC-77X130S	70	43	56	60	103	108	-	M6	130	135	77	12	2	9.5
ASC-77X170S	70	43	96	100	143	148	10	M6	170	175	77	12	2	9.5
ASC-77X210S	70	43	136	140	183	188	10	M6	210	215	77	12	2	9.5
ASC-127x160S	87	55	70	75	131	136	16	M6	160	165	127	14	2.5	9.5
ASC-127x210S	87	55	120	125	181	186	16	M6	210	215	127	14	2.5	9.5
ASC-127x260S	87	55	170	175	231	236	16	M6	260	265	127	14	2.5	9.5
ASC-127X310S	87	55	220	225	281	286	16	M6	310	315	127	14	2.5	9.5
ASC-127X360S	87	55	270	275	331	336	16	M6	360	365	127	14	2.5	9.5

Model	K	K1	K2	K3	L	M	N	O	P	Pull Stud	Weight (kg)
ASC-77X102S	24	27	18	3	77	52	52	42	15	M-52x52PS	2.8
ASC-77X130S	24	27	18	3	77	52	52	42	15	M-52x52PS	3.5
ASC-77X170S	24	27	18	3	77	52	52	42	15	M-52x52PS	4.2
ASC-77X210S	24	27	18	3	77	52	52	42	15	M-52x52PS	4.9
ASC-127x160S	29	32	20	3	126	96	96	90	24	M-96x96PS	9
ASC-127x210S	29	32	20	3	126	96	96	90	24	M-96x96PS	11
ASC-127x260S	29	32	20	3	126	96	96	90	24	M-96x96PS	13
ASC-127X310S	29	32	20	3	126	96	96	90	24	M-96x96PS	15
ASC-127X360S	29	32	20	3	126	96	96	90	24	M-96x96PS	17

Optional Accessories

Please refer to Page 22~53 Zero Point Quick Change Devices

Rectangular Plate

Model: M-52x52 (8001G)

- Size: 150x116x30 mm
- Pull Stud: M-52x52PS
- Weight: 3.2 kg
- Suitable for
ASC-77x102S
ASC-77x130S
ASC-77x170S
ASC-77x210S

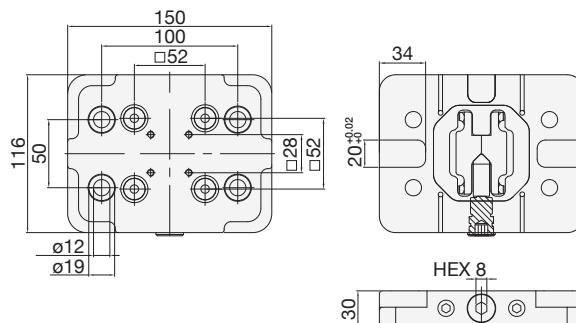

Model: M-96x96 (8051G)

- Size: 192x156x30 mm
- Pull Stud: M-96x96PS
- Weight: 6.4 kg
- Suitable for
ASC-127x160S
ASC-127x210S
ASC-127x260S
ASC-127x310S
ASC-127x360S

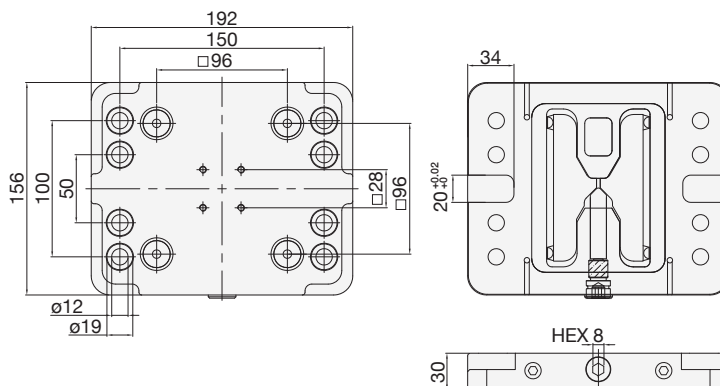

Master Gauging Pallet

Suitable for quick checking the precise alignment of Quick Changing Plates and for concentric alignment of rotary or chucks.

Model: M-52x52 (8010)

- Size: 80x80x27 mm
- Pull Stud: M-52x52PS
- Weight: 1.1 kg



Model: M-96x96 (8058)

- Size: 126x126x27 mm
- Pull Stud: M-96x96PS
- Weight: 2.6 kg



Pull Studs

Can be adapted onto vises or workpieces to use together with any Quick Change Device.

Model: M-52x52PS

- 4 pcs / set
- Weight: 0.16 kg / set



Model: M-96x96PS

- 4 pcs / set
- Weight: 0.28 kg / set



Spacer Studs

Improve the machining accessibility of edges or angles by making a through space between workpieces and Quick Change Devices.

Model: M-52x52SS

- 4 pcs / set
- Weight: 0.27 kg / set



Model: M-96x96SS

- 4 pcs / set
- Weight: 0.4 kg / set



FIVE-AXIS ADJUSTABLE SELF-CENTERING VISE

10

FIVE-AXIS ADJUSTABLE SELF-CENTERING VISE / ASC-M SERIES

Model: ASC-127x130M, 127x160M, 127x210M, 127x260M,
ASC-150x260M



- Special 45° dovetail structure with teeth
- With a pair of mounting holes, ASC-M series can be directly fixed on the 3rd, 4th or 5th-Axis machine bed.
- Purchase an additional Fixed Jaw to enable dual clamping.



ASGM Series

STANDARD ACCESSORIES:

- 4 pcs of Clamp
- 1 pc of Wrench

<p>Vise body is made of High quality Steel (S50C) and its slideways gone through high-frequency hardening to achieve HRC50, which makes the whole part durable.</p>	<p>The vise body can be mounted directly on the machine table by the middle with 2 pieces of M12 screws. This vise also can clamp 2 workpieces by mounting the centre jaw in the middle.</p>	<p>Detachable jaws are made of High quality Tool Steel (SCM440) and gone through carburizing to achieve HRC55. Since both sides are fixed size and able to be used as a datum, users can reverse them to increase clamping range.</p>	<p>The vise's clamping force can achieve 1300KG, the repeatability positioning precision of its clamping center is within ±0.02mm.</p>	<p>The 45° dovetail structure with teeth on the upper jaw ensures the bottom of the workpiece to be firmly clamped.</p>
<p>1</p>	<p>2</p>	<p>3</p>	<p>4</p>	<p>5</p>

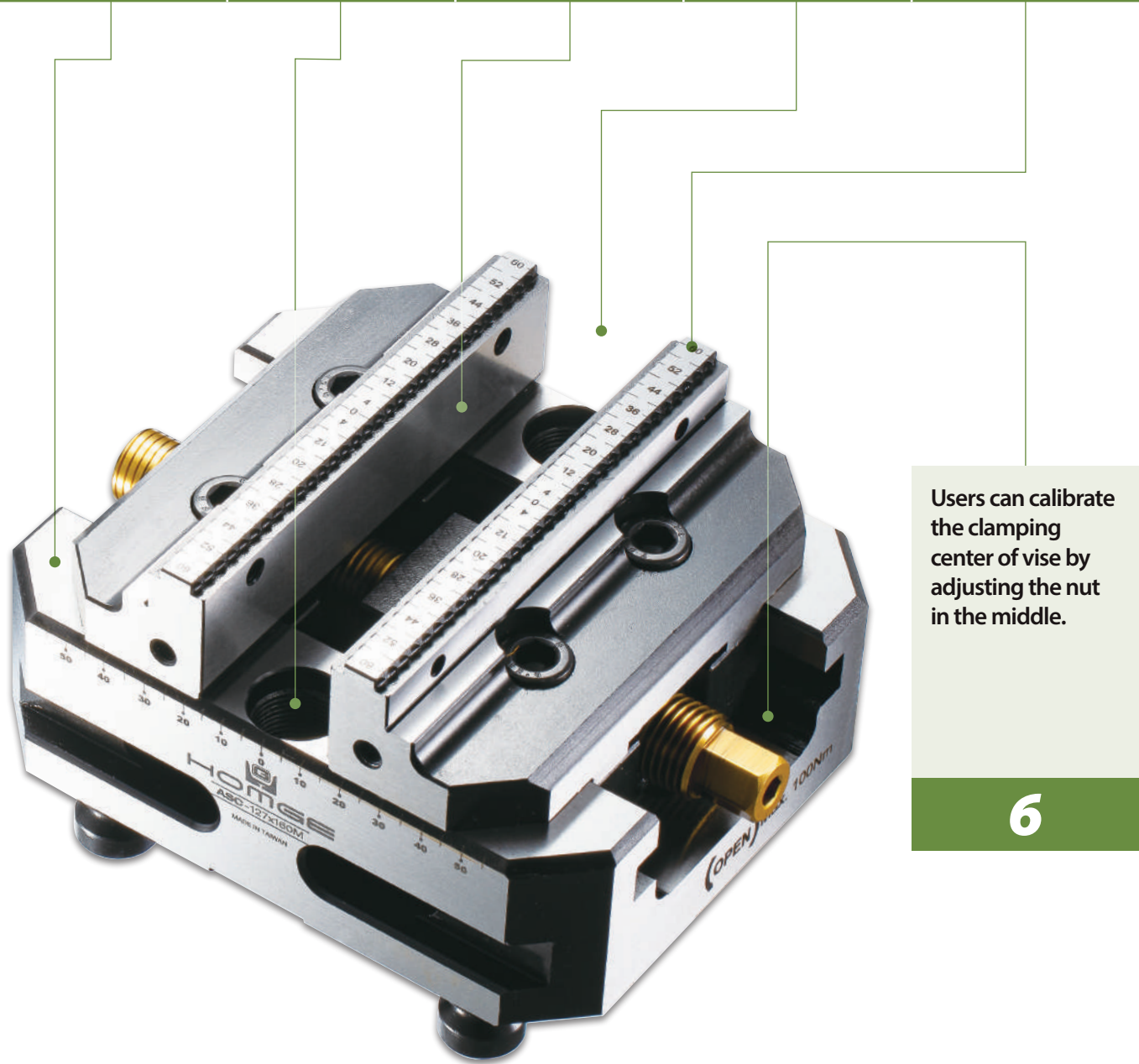

Users can calibrate the clamping center of vise by adjusting the nut in the middle.

6

ASGM Series

Model: ASC-127x130M, 127x160M, 127x210M, 127x260M,
ASC-150x260M



ASC-127x130M

Size 135x127x80 mm

Weight (kg) 7.3



ASC-127x160M

Size 165x127x80 mm

Weight (kg) 7.5



ASC-127x210M

Size 215x127x80 mm

Weight (kg) 8.5



ASC-127x260M

Size 265x127x80 mm

Weight (kg) 10



ASC-150x260M

Size 265x150x80 mm

Weight (kg) 13.5

Optional Accessories



Center Jaw



Flexi Jaws

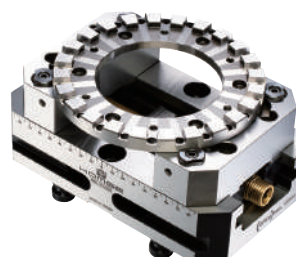

OPTIONAL ACCESSORIES:

- Rectangular Plate
- Master Gauging Pallet
- Pull Studs
- Spacer Studs

Please refer to Page 22~53
Zero Point Quick Change Devices

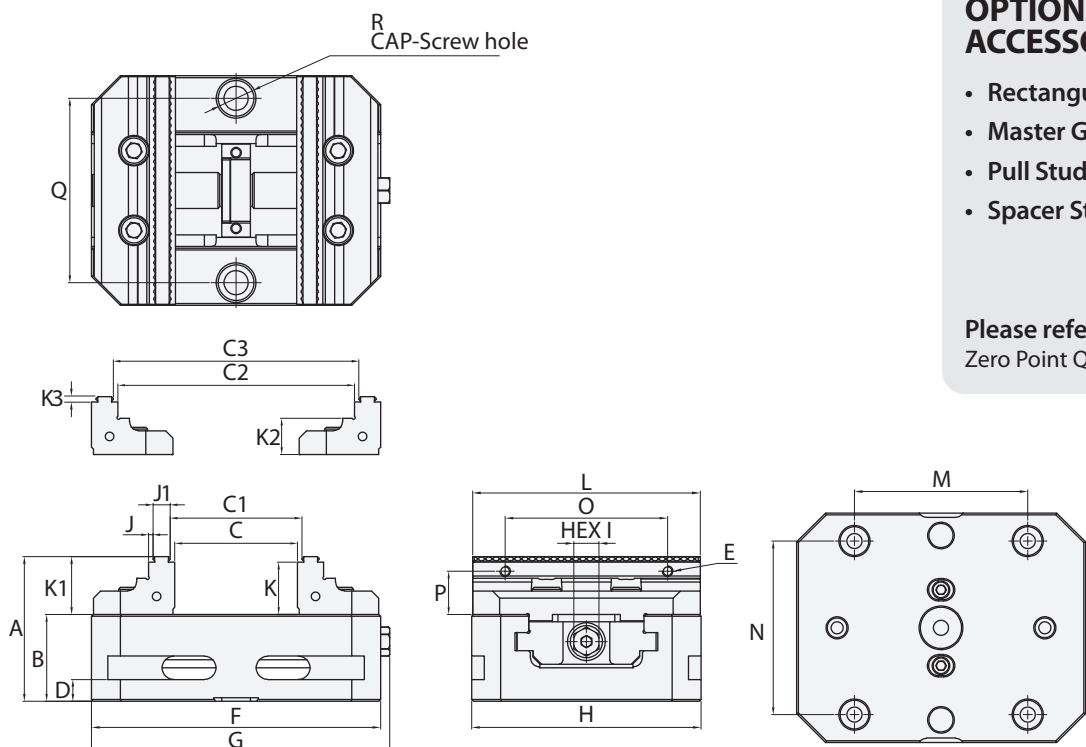

SPECIFICATIONS (Material: Vise body S50C. Hardness: HRC 50/ Detachable Jaws SCM440. Hardness: HRC 55)

Unit: mm

Model	A	B	C	C1	C2	C3	D	E	F	G	H	I	J	J1
ASC-127x130M	80	48	40	45	101	106	12	M6	130	135	127	14	2.5	9.5
ASC-127x160M	80	48	70	75	131	136	12	M6	160	165	127	14	2.5	9.5
ASC-127x210M	80	48	120	125	181	186	12	M6	210	215	127	14	2.5	9.5
ASC-127x260M	80	48	170	175	231	236	12	M6	260	265	127	14	2.5	9.5
ASC-150x260M	80	48	170	175	231	236	12	M6	260	265	150	14	2.5	9.5

Model	K	K1	K2	K3	L	M	N	O	P	Q	R	Pull Stud	Weight(kg)
ASC-127x130M	29	32	20	3	126	96	96	90	24	102	M12	M-96x96PS	7.3
ASC-127x160M	29	32	20	3	126	96	96	90	24	102	M12	M-96x96PS	7.5
ASC-127x210M	29	32	20	3	126	96	96	90	24	102	M12	M-96x96PS	8.5
ASC-127x260M	29	32	20	3	126	96	96	90	24	102	M12	M-96x96PS	10
ASC-150x260M	29	32	20	3	149	96	96	90	24	120	M12	M-96x96PS	13.5

FIVE-AXIS ADJUSTABLE SELF-CENTERING VISE

Model: ASC-130x310K
ASC-160x310K



- High rigidity due to reinforced stud bolt seat and hard jaws, suitable for machining large workpieces.
- Applicable to all machine tool models. With the patented center positioning threaded pin, users can regulate clamping center easily and rapidly.
- All ASC-Series Vises are dedicated to consistency in materials and manufacturing processes.

ASG-K Series

STANDARD ACCESSORIES:

- 4 pcs of Clamp
- 1 pc of Wrench



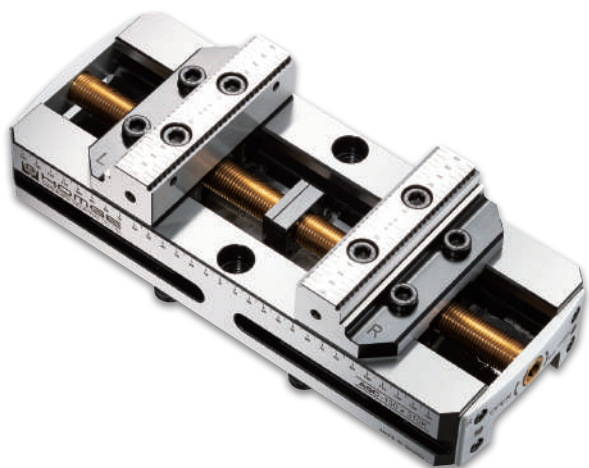

ASC-130x310K



ASC-160x310K

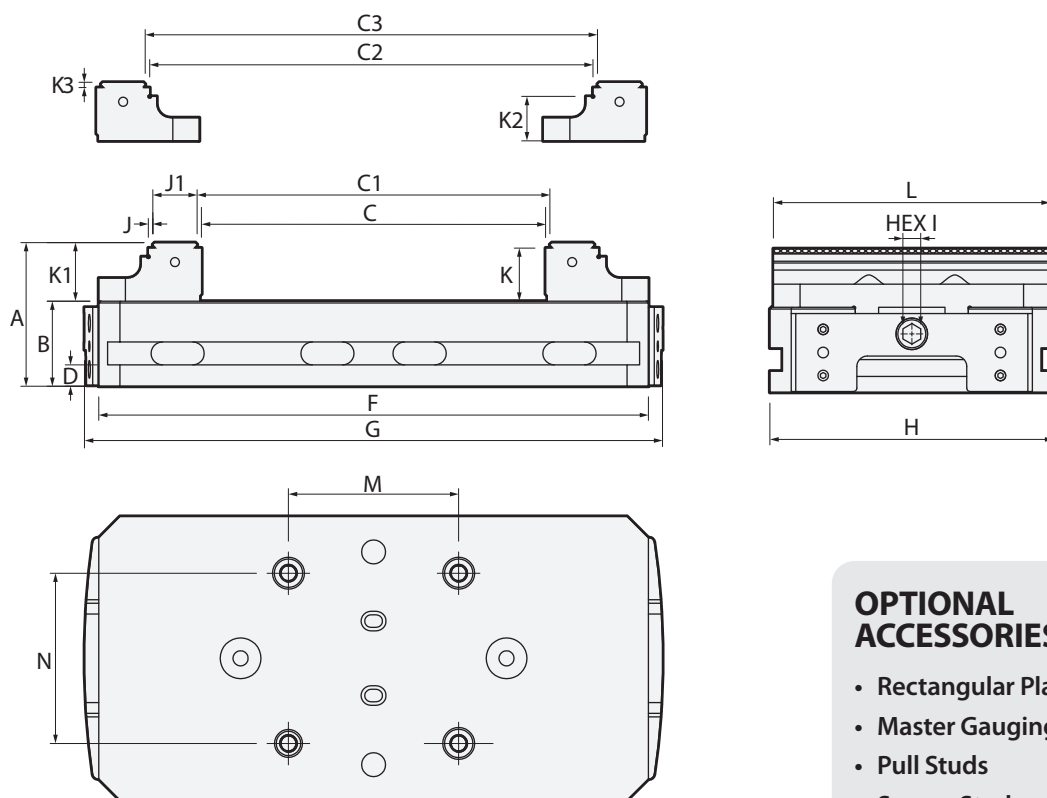

OPTIONAL ACCESSORIES:

- Rectangular Plate
- Master Gauging Pallet
- Pull Studs
- Spacer Studs

Please refer to Page 22~53
Zero Point Quick Change Devices

SPECIFICATIONS (Material: Vise body S50C. Hardness: HRC 50/ Detachable Jaws SCM440. Hardness: HRC 55)

Unit: mm

Model	A	B	C	C1	C2	C3	D	F	G	H	I	J
ASC-130x310K	81	48	194	199	250	255	12	310	326	130	10	2.5
ASC-160x310K	81	48	194	199	250	255	12	310	326	160	10	2.5

Model	J1	K	K1	K2	K3	L	M	N	Pull Stud	Weight (kg)
ASC-130x310K	25	30	33	25	3	126	96	96	M-96x96PS	13.6
ASC-160x310K	25	30	33	25	3	126	96	96	M-96x96PS	17.4

FIVE-AXIS COMPACT MULTI-POWER VISE

Model: ACM-130, 160

16

FIVE-AXIS COMPACT MULTI-POWER VISE



- Suitable for CNC 5-Axis Machining Centers, horizontal and vertical CNC Machining Centers
- Shortest Length with **Big Jaw Opening**
- Extremely High Accuracy and Repeatability
- Special MULTI-POWER design enhances clamping force of **0~5000KG**

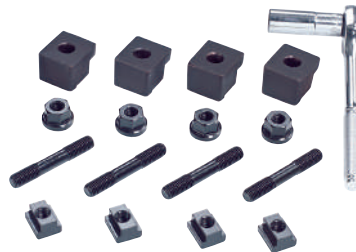

STANDARD ACCESSORIES:

- 2 pcs of Alignment Wedge
- 4 pcs of Clamp
- 1 pc of Wrench

OPTIONAL ACCESSORIES:

- Serrated Jaws
- Soft Jaws

Vise body is made of **Ductile Iron** above **FCD 60** grade and its slideways are **hardened to HRC 52**, which makes the vise tensile strength with high precision accuracy.

Vise jaws are made of **High quality Tool Steel (SCM440)** and Hardened to achieve **HRC 55**, which makes vise clamp the workpieces easily and firmly.

Special Leadscrew Covers protect Leadscrew from swarf and avoid any possible damage to internal parts.

Compact design with **big jaw opening**, which enhances machine space utilization.

The patented **MULTI-POWER SYSTEM** is built of high grade **BEARING STEEL** which doubles the clamping force. Adjustable clamping force **0~5000kg**. With this special patented system the pressure is more consistent and eliminates oil leakage and maintenance problems associated with Hydraulic Vises.

1

2

3

4

5

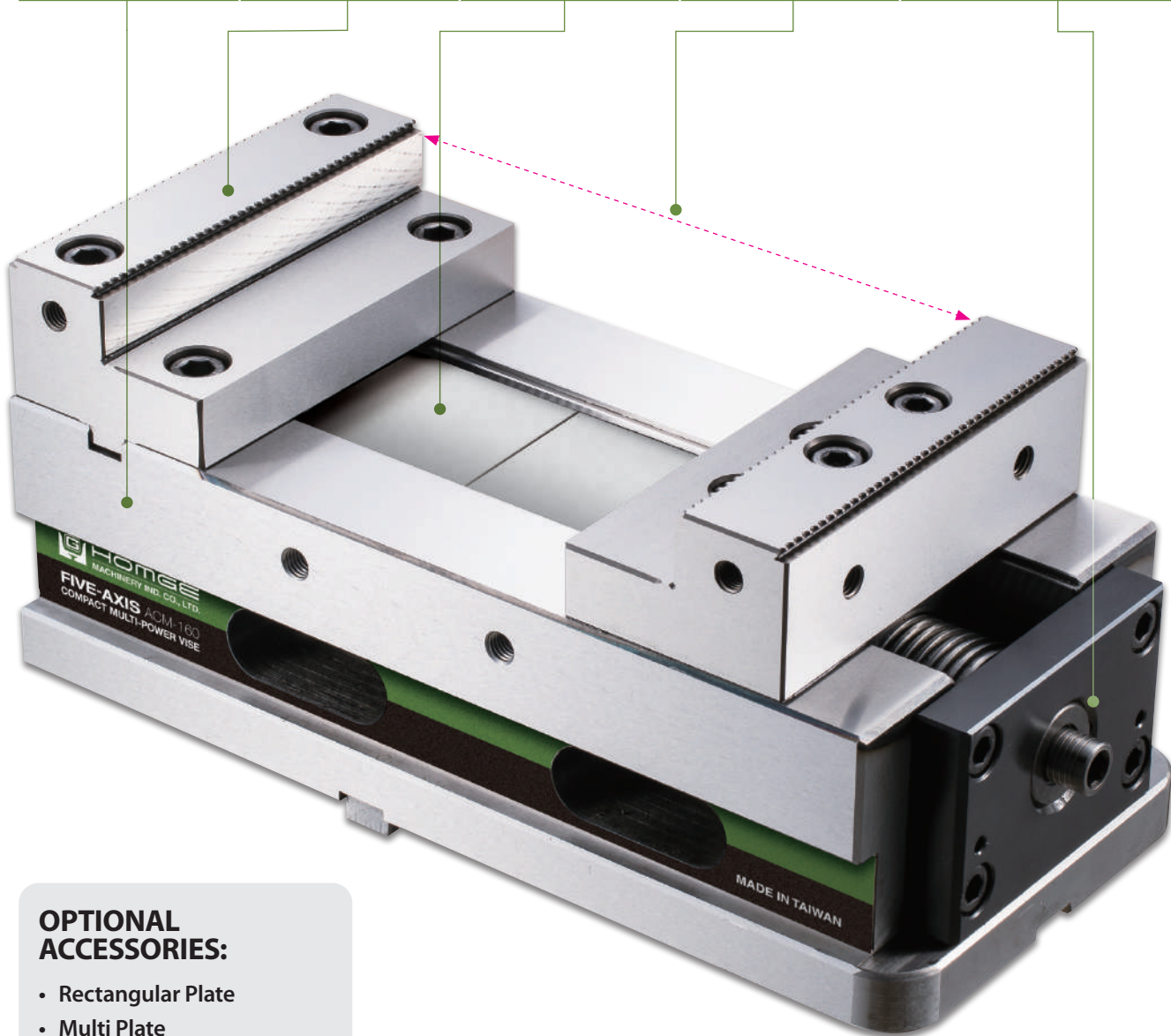

OPTIONAL ACCESSORIES:

- Rectangular Plate
- Multi Plate
- Pull Studs
- Spacer Studs

Please refer to Page 22~53
Zero Point Quick Change Devices

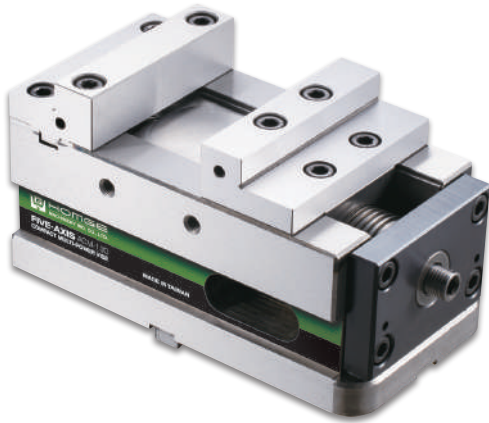
ACM-130

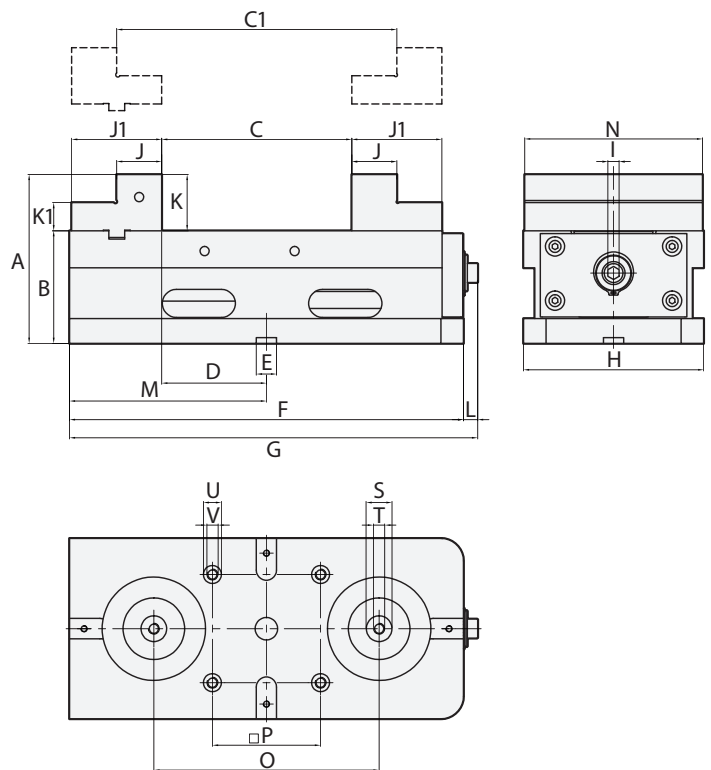
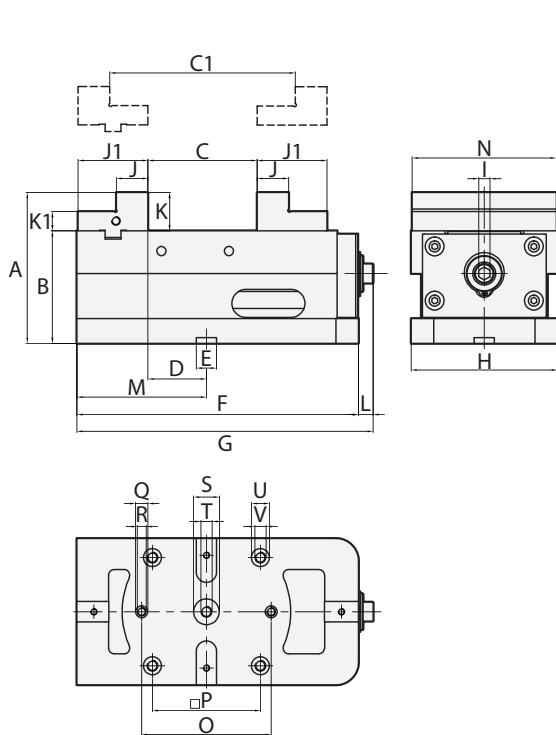
ACM-160

SPECIFICATIONS (Material: Vise body S50C: HRC 50 / Jaws SCM440: HRC 55)

Unit: mm

Model	A	B	C	C1	D	E	F	G	H	I	J	J1	K	K1	L	M	N	O	P
ACM-130	134	100	105	173	52	18	250	263	130	10	28	62	34	17	13	115	128	115	96
ACM-160	150	100	167	247	93	18	350	363	160	10	40	80	50	25	13	175	158	200	96

Model	Q	R	S	T	U	V	Max. Clamping Force	Weight (kg)
ACM-130	Ø11H7	M8x1.25P	Ø23H7	M10x1.5P	Ø16H7	M10x1.5P	5000kg	22
ACM-160	-	-	Ø23H7	M10x1.5P	Ø16H7	M10x1.5P	5000kg	40

FIVE-AXIS COMPACT VISE

Model: ACK-127x160, 127x210

- Clamps in a single direction, ensuring repeatable positioning precision within **±0.01mm**.
- Integrates with 52/96 zero point quick change devices, enhancing workflow.
- Special **Angle-Lock System** automatically pulls the workpiece down to the accurate position.
- Suitable for precision four- and five-axis CNC machine tools, indexing tables, all kinds of vertical or horizontal machining centers.

OPTIONAL ACCESSORIES:

- Serrated Jaws
- Soft Jaws

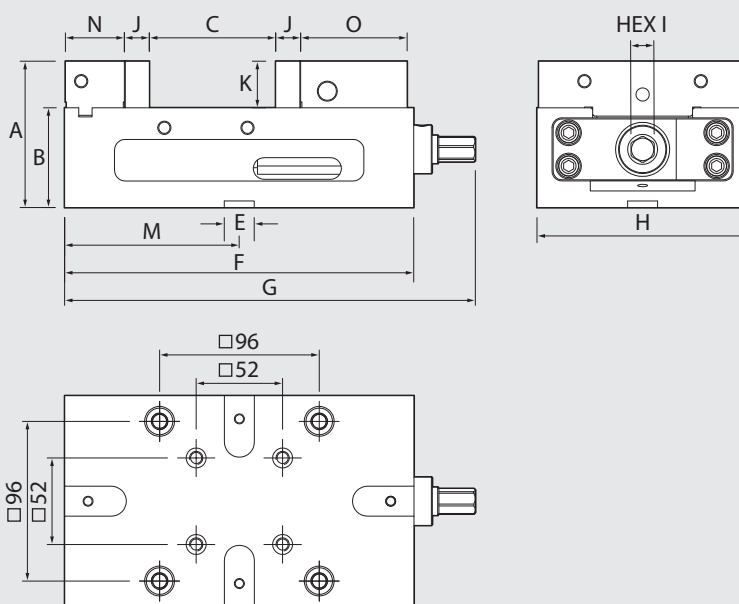
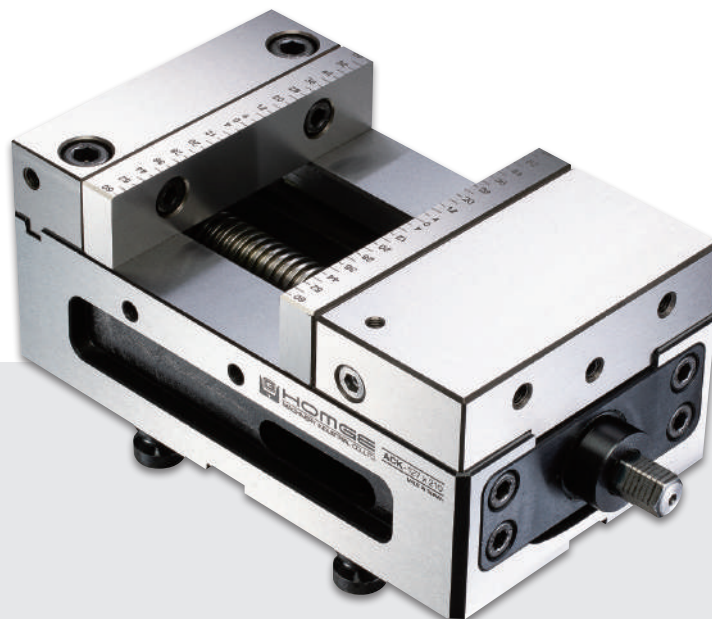

SPECIFICATIONS (Material: Vise body S50C. Hardness: HRC 50 / Jaws SCM440. Hardness: HRC 55)

Unit: mm

Model	A	B	C	C1	E	F	G	H	I
ACK-127x160	88	60±0.01	29.5	31	18	160	193	127	14
ACK-127X210	88	60±0.01	79.5	81	18	210	247	127	14

Model	J	K	M	N	O	Pull Stud	Weight (kg)
ACK-127x160	15	28	80	35.5	64	M-52x52PS M-96x96PS	10.4
ACK-127X210	15	28	105	35.5	64	M-52x52PS M-96x96PS	12

CNC COMPACT MULTI-POWER SUPER VISE

Model: ACM-100S, 160S



- Shortest Vise Body
- Big Jaw Opening
- Compact Multi-Power System clamping force **0-5000 kg**



STANDARD ACCESSORIES:

- 2 pcs of Alignment Wedge
- 4 pcs of Clamp
- 1 pc of Wrench

OPTIONAL ACCESSORIES:

- Front / Back Jaws

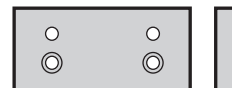

<p>Vise body is made of Ductile Iron above FCD 60 grade and its slideways are hardened to HRC 50, which make the vise tensile strength with high precision accuracy.</p>	<p>Vise jaws are made of High Quality Tool Steel (SCM440) and Hardened to achieve HRC 50, which makes vise clamp the workpieces easily and firmly.</p>	<p>Compact design with big jaw opening, which enhances machine space utilization. Suitable for all kinds of horizontal and vertical CNC Machining Centers, also Tapping Centers.</p>	<p>Special Leadscrew Covers protect Leadscrew from swarf and avoid any possible damage to internal parts.</p>	<p>The patented MULTI-POWER SYSTEM is built of high grade BEARING STEEL which doubles the clamping force. Adjustable clamping force of 0-5000kg. With this special patented system, the pressure is more consistent and eliminates oil leakage and maintenance problems associated with Hydraulic Vises.</p>
1	2	3	4	5

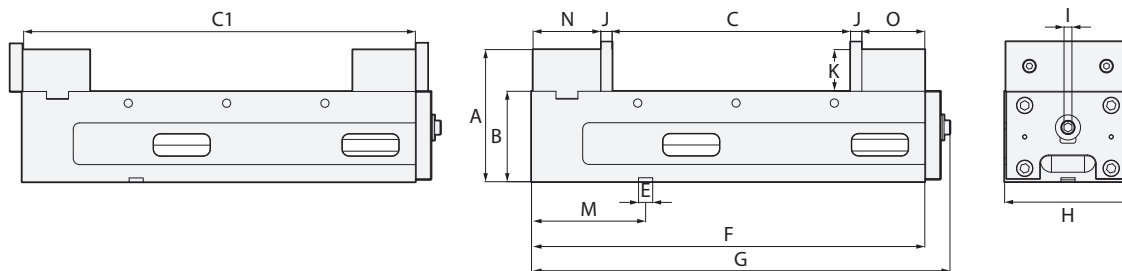
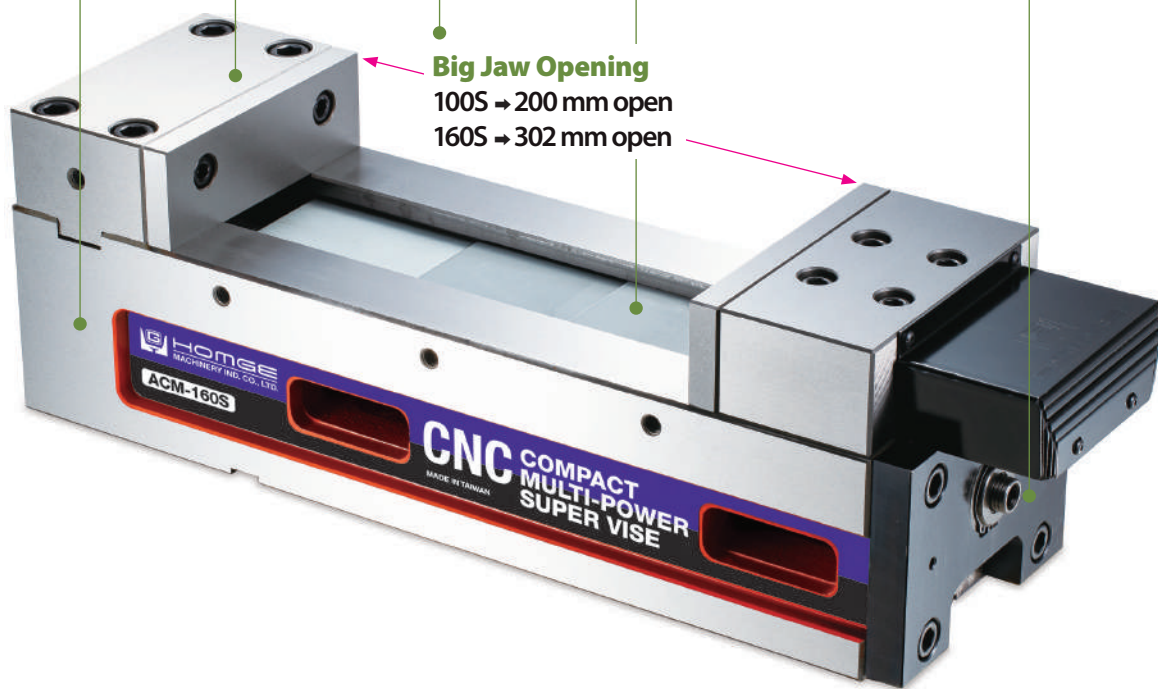

SPECIFICATIONS (Material: Vise body: Ductile Iron FCD 60, HRC 50 / Fixed Jaw & Moveable Jaw: S50C, HRC 50)

Unit: mm

Model	A	B	C	C1	E	F	G	H	I	J	K	M	N	O	Max. Clamping Force	Weight (kg)
ACM-100S	140	100±0.01	200	350	18	352	392	100	10	15	40	145	60	60	4000	31
ACM-160S	168	115±0.01	302	498	18	500	532	161	10	15	53	145	86	80	5000	63

ZERO POINT QUICK CHANGE DEVICES

Quick Change Device and its accessories (including Base Plate, Adapter Plate 52/96, Column, Riser Block, Multi Plate, Clamping Bridge, etc.) are highly modular, and their combination can satisfy different machine tools, fixtures and processes

- Installing Quick Change Device can greatly save the positioning time of the fixture during change over
- Installing Quick Change Device in the entire production line can effectively reduce the accumulated tolerance
- Fixtures can be rotated 90 degrees while maintaining centering accuracy
- Support common stud specifications in the market (52/ 96 mm bolt distance)
- Various specifications for flexible configuration, especially suitable for 4, 5-axis machine tool with limited bed space

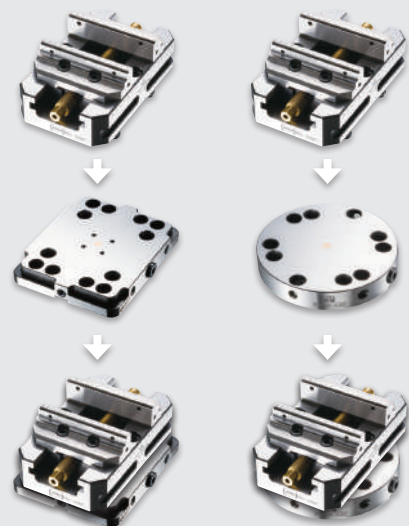

Base Plate

Base plate is made of High quality Steel (S50C) with heat treatment of HRC 46, then grounded precisely to ensure the durability and accuracy.

Repeatability: < 0.008 mm

Pull stud spacing: 52mm or 96mm

- 1** Mechanical clamping with a screw or fast actuation system
- 2** 4xM5 threads are used as positioning support for vises
- 3** 20 mm keyways for axial alignment
- 4** A flexible positioning solution for vertical and horizontal machining centers. Suitable for using on 3- and 5-axis machine tables and 4th axis rotary or trunnion systems.



FRONT

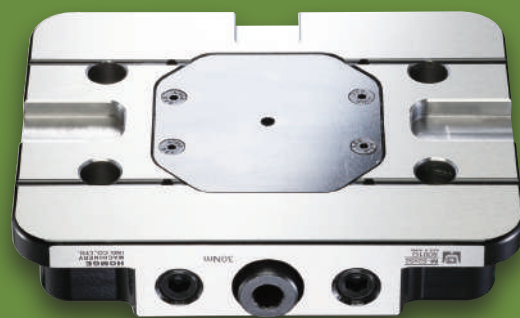

BACK

Rectangular Plate

with clamping edge & mounting bores



M-52x52 (8001G)

Size	150x116x30 mm
Pull Stud No.	M-52x52PS
Mounting Holes	100x50 mm
Weight (kg)	3.2



M-96x96 (8051G)

Size	192x156x30mm
Pull Stud No.	M-96x96PS
Mounting Holes	150x50/100 mm
Weight (kg)	6.4

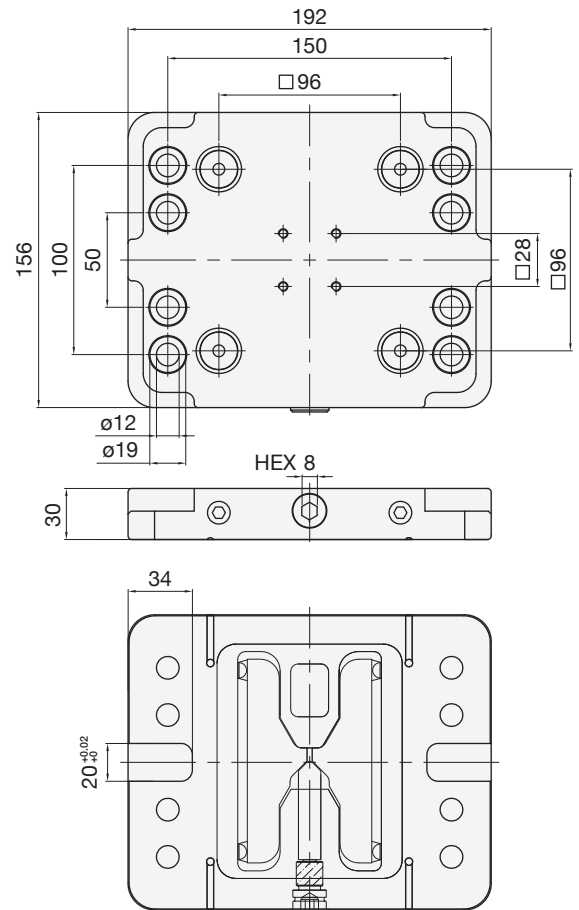
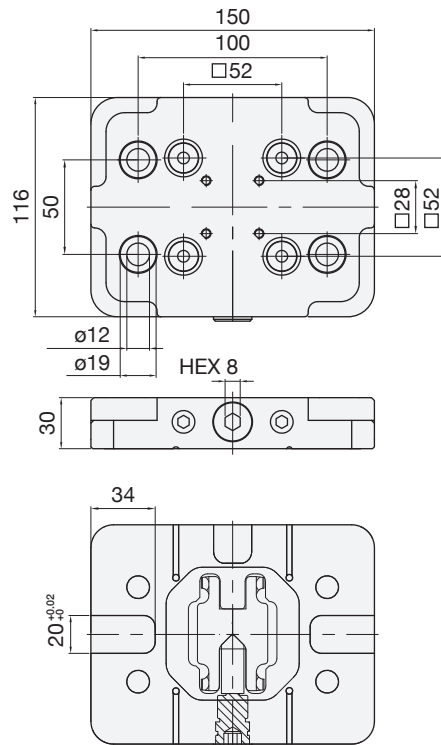

Rectangular Plate

without clamping edge & mounting bores



M-52x52 (8002G)

Size 150x116x30 mm

Pull Stud No. M-52x52PS

Mounting Holes -

Weight (kg) 4.2

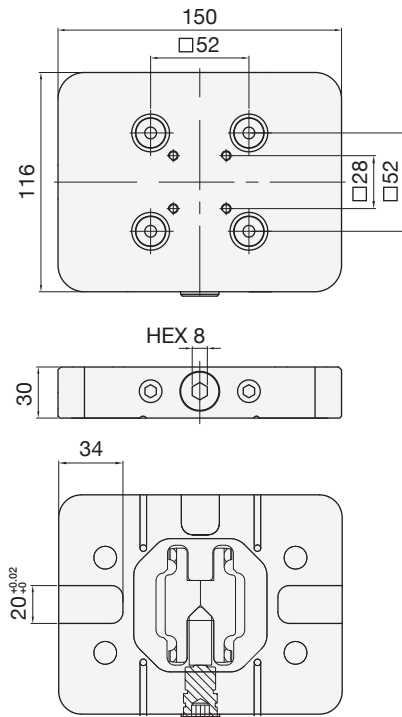

M-96x96 (8052G)

Size 192x156x30 mm

Pull Stud No. M-96x96PS

Mounting Holes -

Weight (kg) 7.8

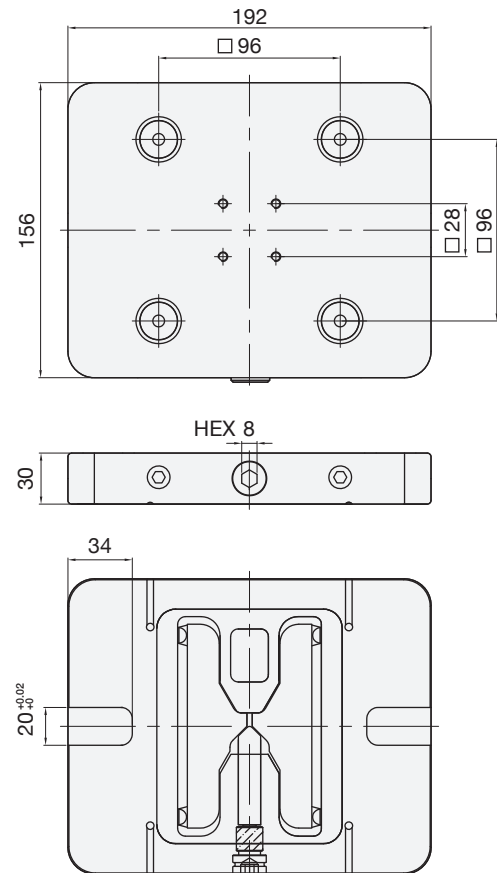

Round Plate

with clamping edge & mounting bores



M-52x52 (8004G)

Size	Ø116x30 mm
Pull Stud No.	M-52x52PS
Mounting Holes	96 mm
Weight (kg)	2.2

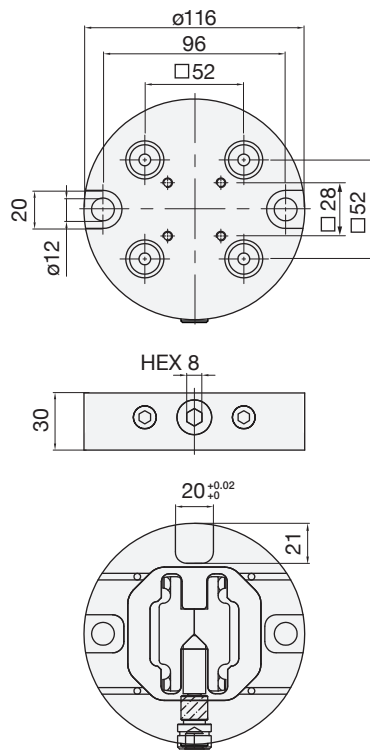

M-96x96 (8053G)

Size	Ø176x30 mm
Pull Stud No.	M-96x96PS
Mounting Holes	150/ 60x126 mm
Weight (kg)	5.3

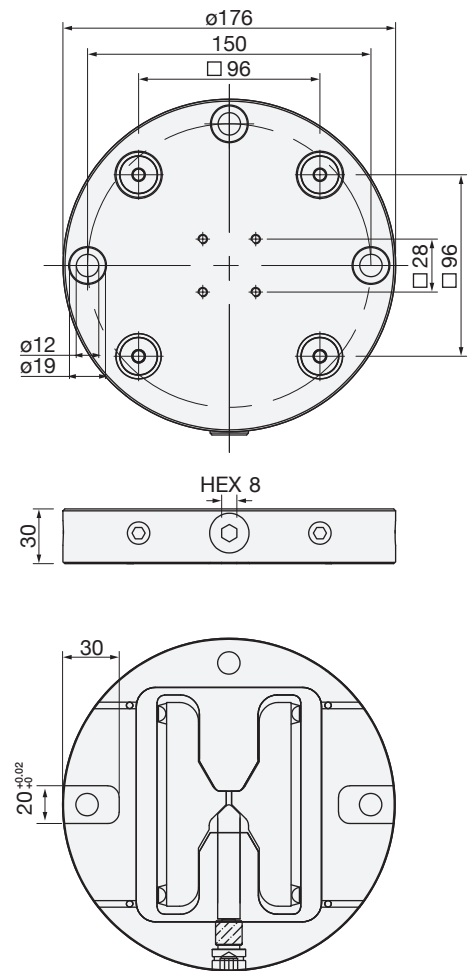

Round Plate

without clamping edge & mounting bores



M-52x52 (8005G)

Size $\varnothing 116 \times 30$ mm

Pull Stud No. M-52x52PS

Mounting Holes -

Weight (kg) 2.4

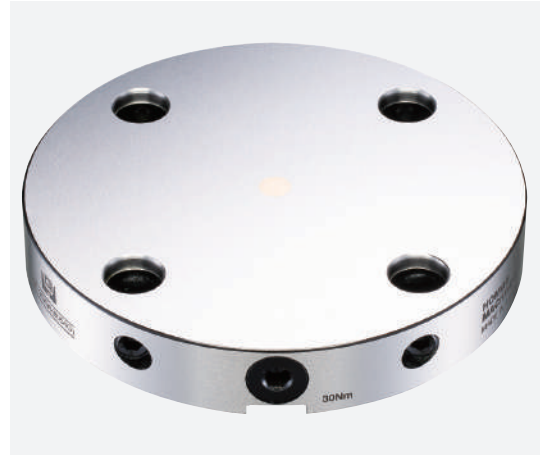

M-96x96 (8054G)

Size $\varnothing 176 \times 30$ mm

Pull Stud No. M-96x96PS

Mounting Holes -

Weight (kg) 6

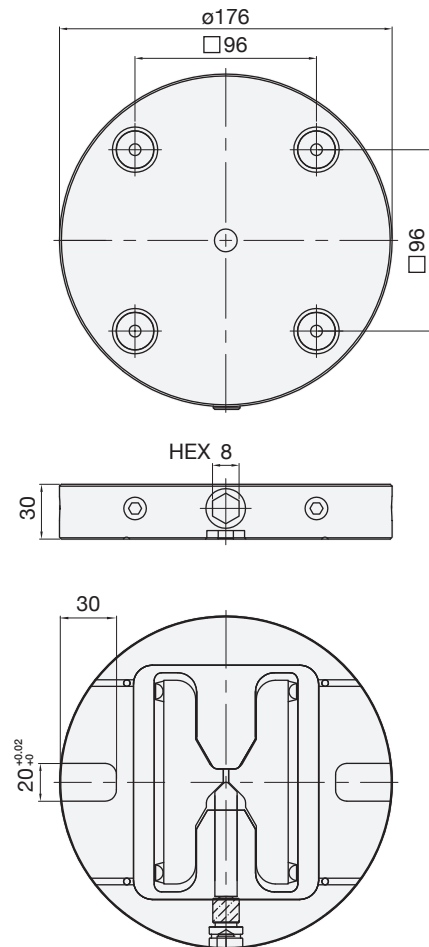
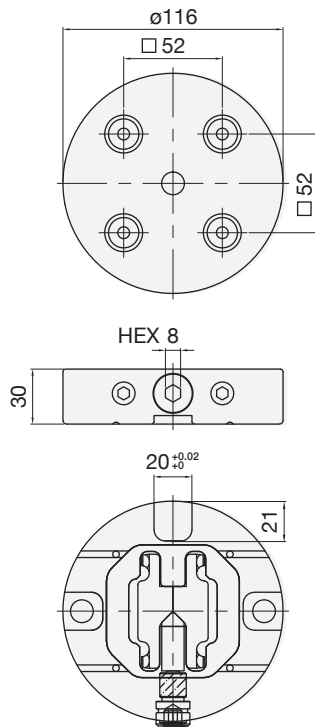

Round Plate

with mounting bores for tables with 90° grooves



M-96x96 (8057G)

Size	Ø246x30 mm
Pull Stud No.	M-96x96PS
Mounting Holes	4x90°/ Diameter 220 mm
Weight (kg)	11.6

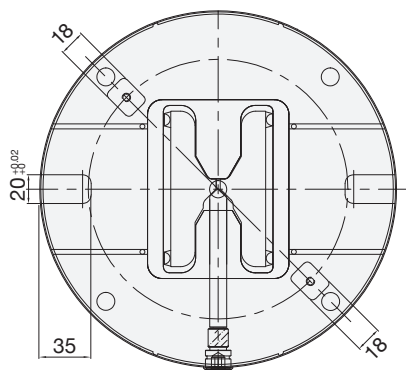
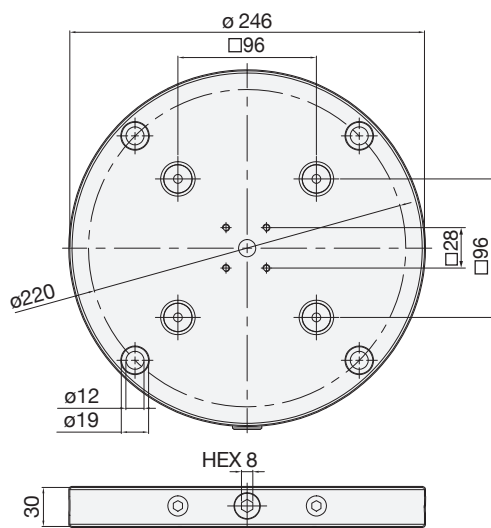

without mounting bores for tables with 90° grooves

M-96x96 (8059G)

Size	Ø246x30 mm
Pull Stud No.	M-96x96PS
Mounting Holes	-
Weight (kg)	12.2

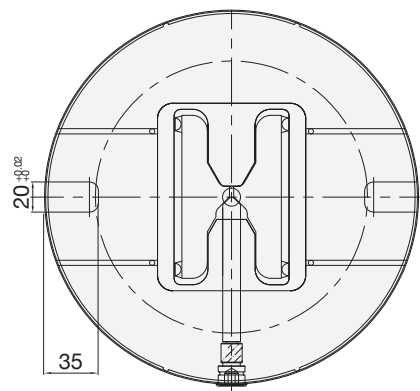
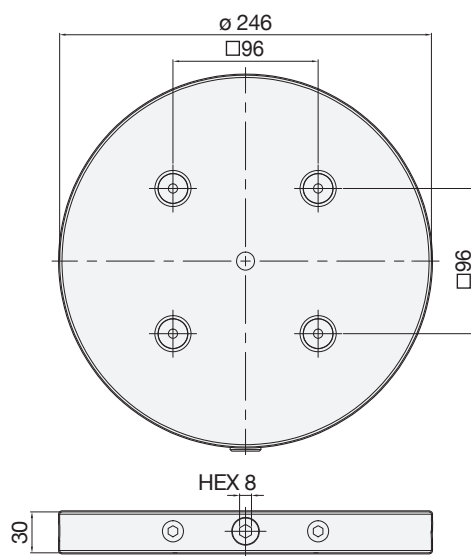

Grid Plate



M-52x52 (8011G)

Size 104x104x30 mm

Pull Stud No. M-52x52PS

Mounting Holes 82x82 mm

Weight (kg) 2.3

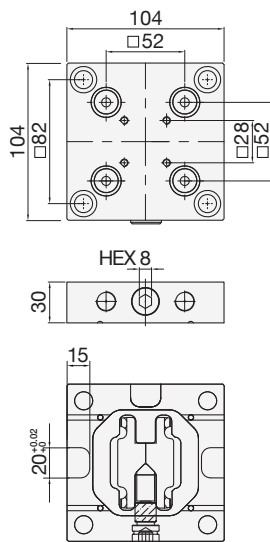

M-96x96 (80522G)

Size 192x192x30 mm

Pull Stud No. M-96x96PS

Mounting Holes 150x120 mm

Weight (kg) 7.6

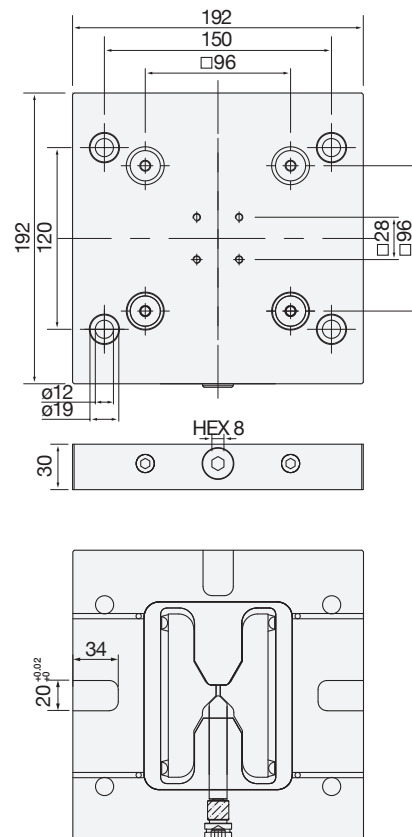

Adapter Plate-52/96

At the beginning, vise and the Plate of 96mm system was purchased. If user needs to process small workpieces in the future, it is recommended to use a modular Adapter Plate, which can quickly change the 96 system to 52 system.



Adapter Plate

Rectangular Adapter Plate



M-52x96 (8003G)

Size	150x126x30 mm
Pull Stud No.	M-52x52PS / M-96x96PS
Mounting Holes	96x96 mm
Weight (kg)	4.9

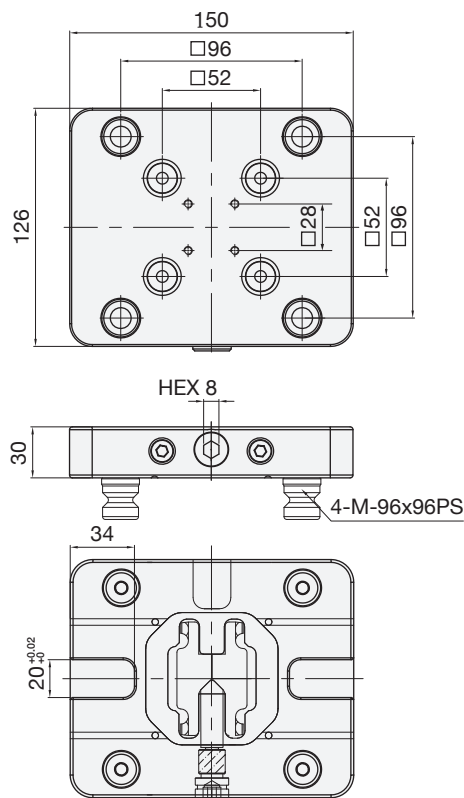

Round Adapter Plate



M-52x96 (8006G)

Size	$\varnothing 157$ x30 mm
Pull Stud No.	M-52x52PS / M-96x96PS
Mounting Holes	100/ 96x96 mm
Weight (kg)	4.5

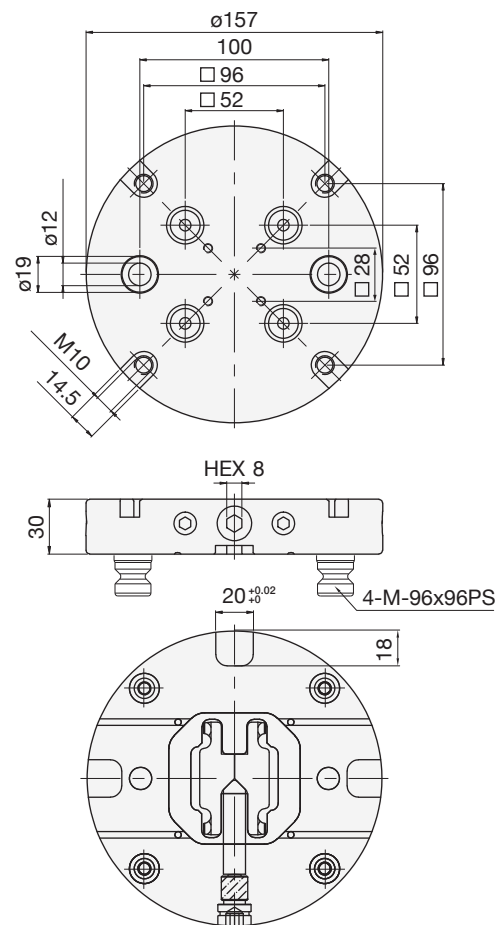

Adapter Plate for 3-Jaw Chuck

3 Jaw Chuck Adapter Plate for M-52x52

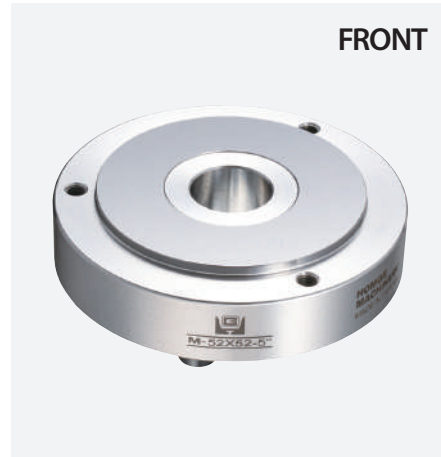

M-52x52 (4")

Size	Ø112x30 mm
Pull Stud No.	M-52x52PS
Mounting Holes	M8
Weight (kg)	2

M-52x52 (5")

Size	Ø132x30 mm
Pull Stud No.	M-52x52PS
Mounting Holes	M8
Weight (kg)	2.9

M-52x52 (6")

Size	Ø167x30 mm
Pull Stud No.	M-52x52PS
Mounting Holes	M10
Weight (kg)	4.6

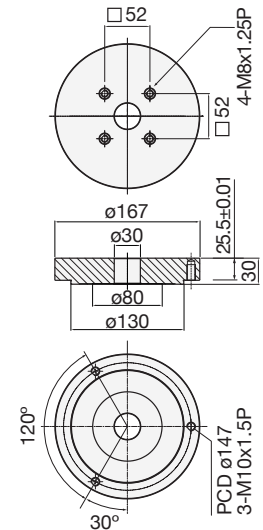
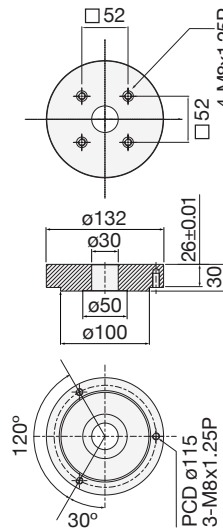
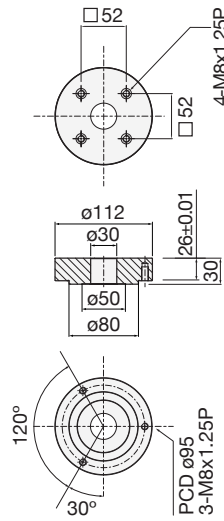

3 Jaw Chuck Adapter Plate for M-96x96

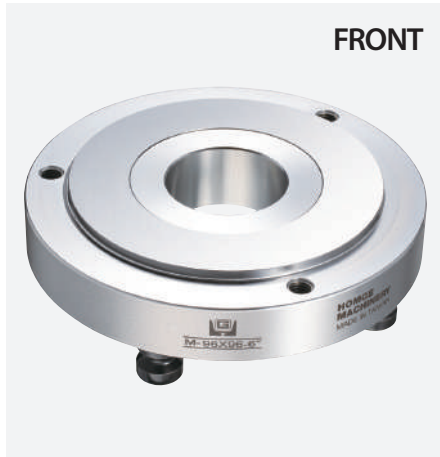

M-96x96 (6")

Size	Ø167x30 mm
Pull Stud No.	M-96x96PS
Mounting Holes	M10
Weight (kg)	4.6

M-96x96 (7")

Size	Ø193x30 mm
Pull Stud No.	M-96x96PS
Mounting Holes	M10
Weight (kg)	6

M-96x96 (8")

Size	Ø203x30 mm
Pull Stud No.	M-96x96PS
Mounting Holes	M10
Weight (kg)	6.7

M-96x96 (9")

Size	Ø233x30 mm
Pull Stud No.	M-96x96PS
Mounting Holes	M12
Weight (kg)	8.9

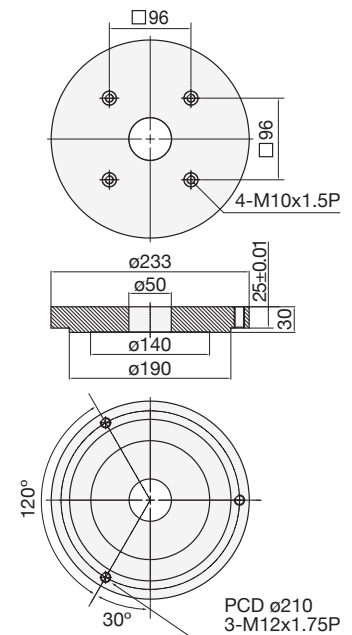
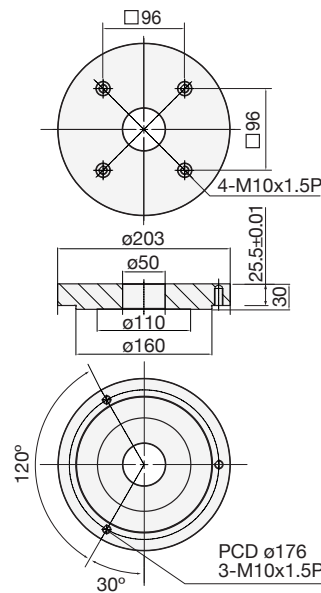
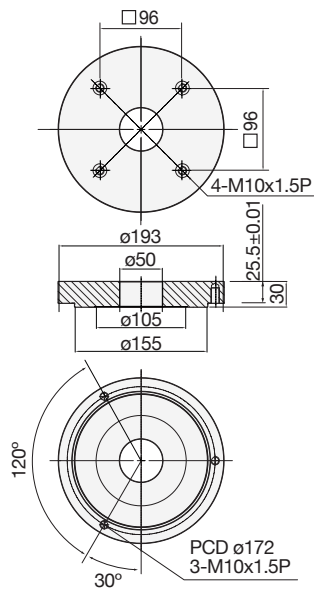
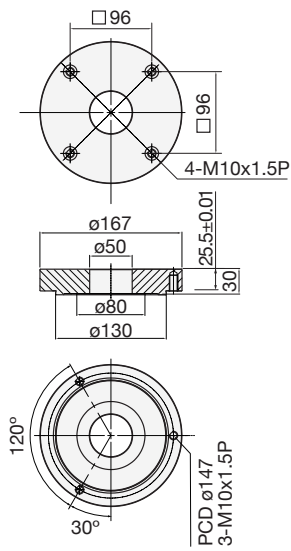

Column

Double-sided positioning tombstone inherits the characteristics of the positioning plate and can utilize the processing space of the machine tool. Suitable for 3-axis machine tool users who often apply dual-sided processing.

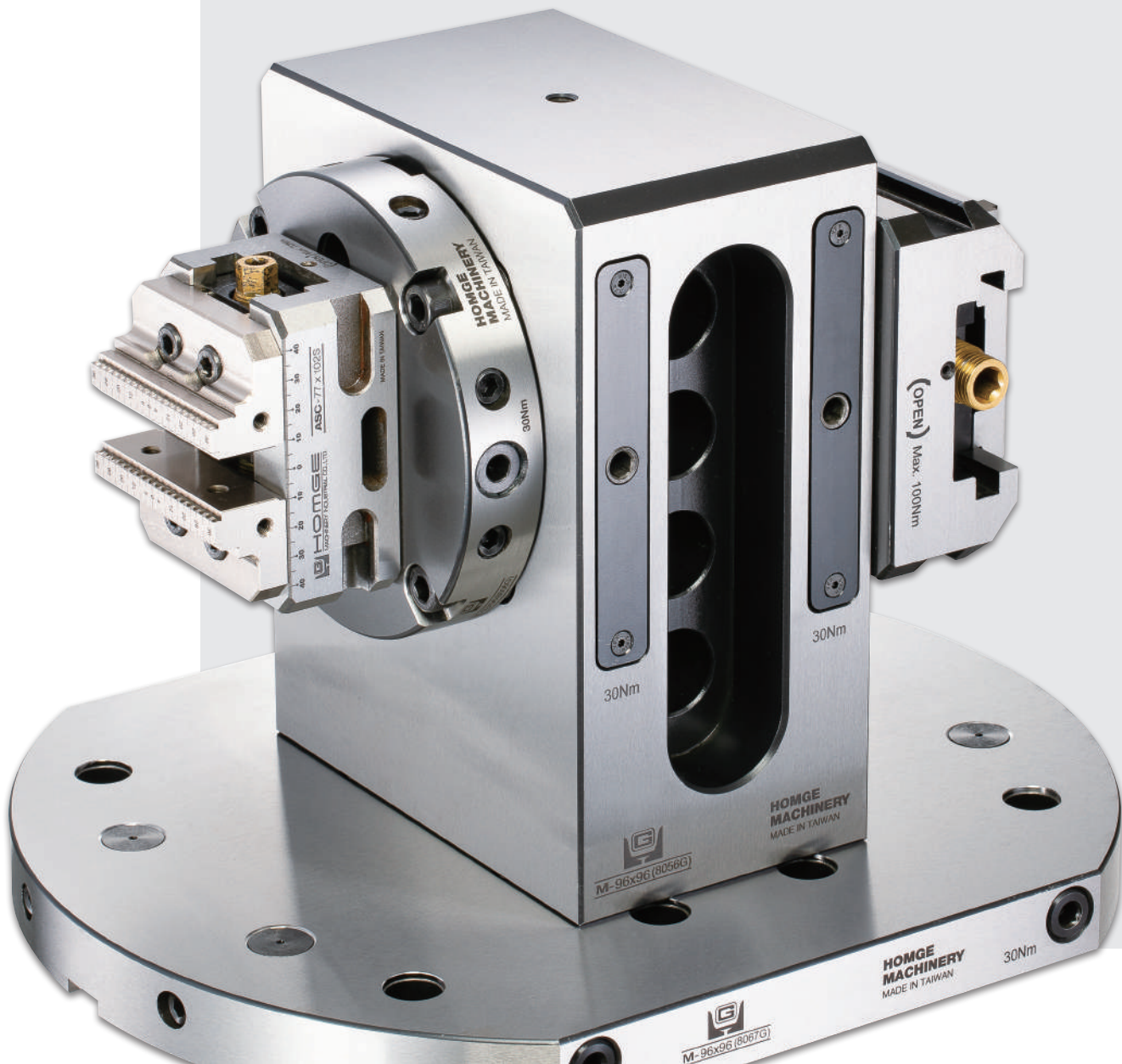

Twin Base



M-52x52 (8008G)

Size 146x76x168 mm

Pull Stud No. M-52x52PS

Mounting Holes -

Weight (kg) 15.5



M-96x96 (8056G)

Size 192x118x247 mm

Pull Stud No. M-96x96PS

Mounting Holes -

Weight (kg) 36.5

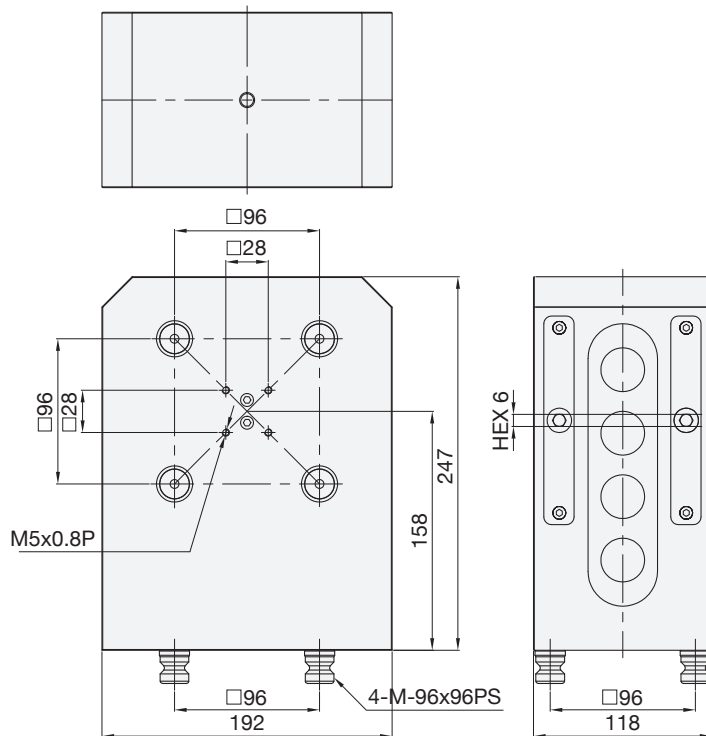
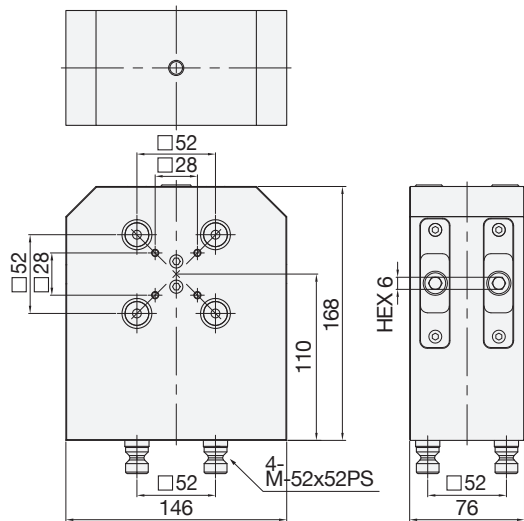

Master Gauging Pallet

Suitable for quick checking the precise alignment of Quick Changing Plates and for concentric alignment of rotary or chucks.

How it works:

After clamping the gauging pallet in a Quick Change Device - plate, the axial alignment of the Quick Change Device - plate is done by probing the jig-ground sides of the gauging pallet. For a concentric alignment the inner diameter of the gauging pallet can be used.

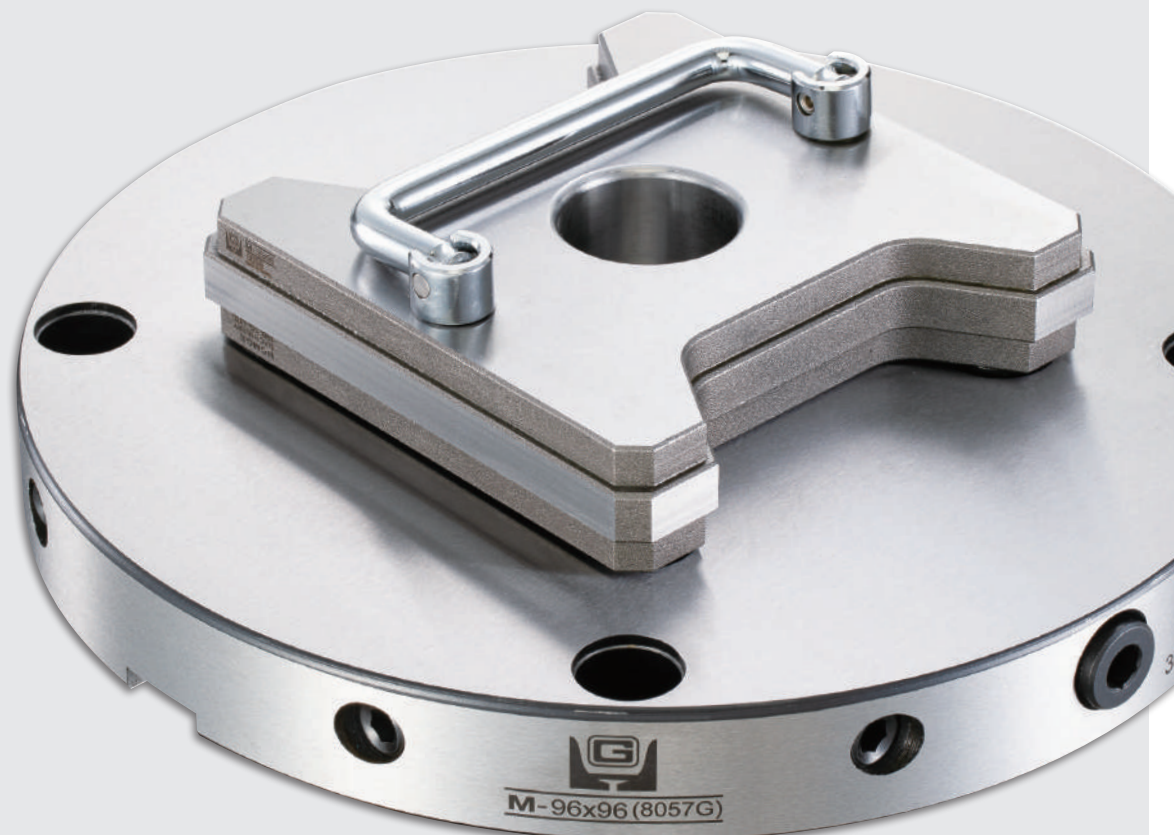



M-52x52 (8010)

Size	80x80x27 mm
Pull Stud No.	M-52x52PS
Weight (kg)	1.1

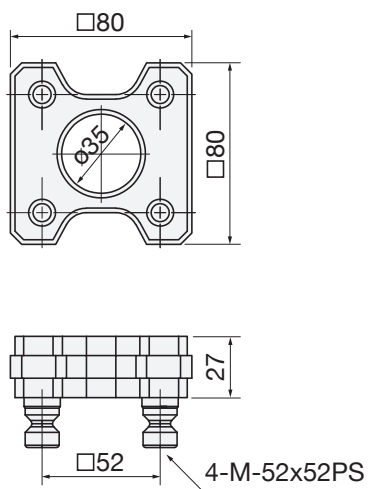

M-96x96 (8058)

Size	126x126x27 mm
Pull Stud No.	M-96x96PS
Weight (kg)	2.6

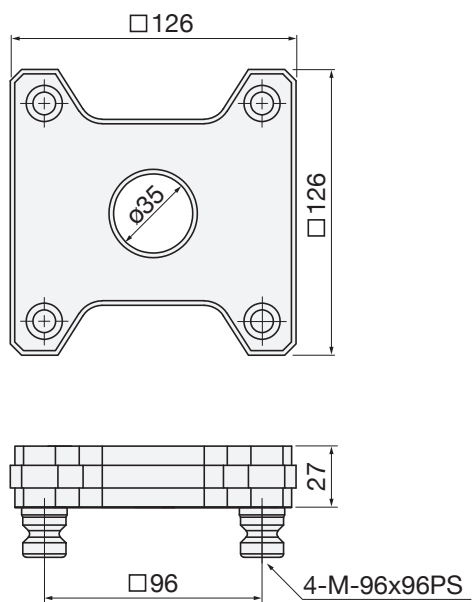

Riser Block

Riser Block provides sufficient space for tool feed by reducing the interference between the bed and the machining tool. Suitable for multi-axis machining and one-piece formed processes.

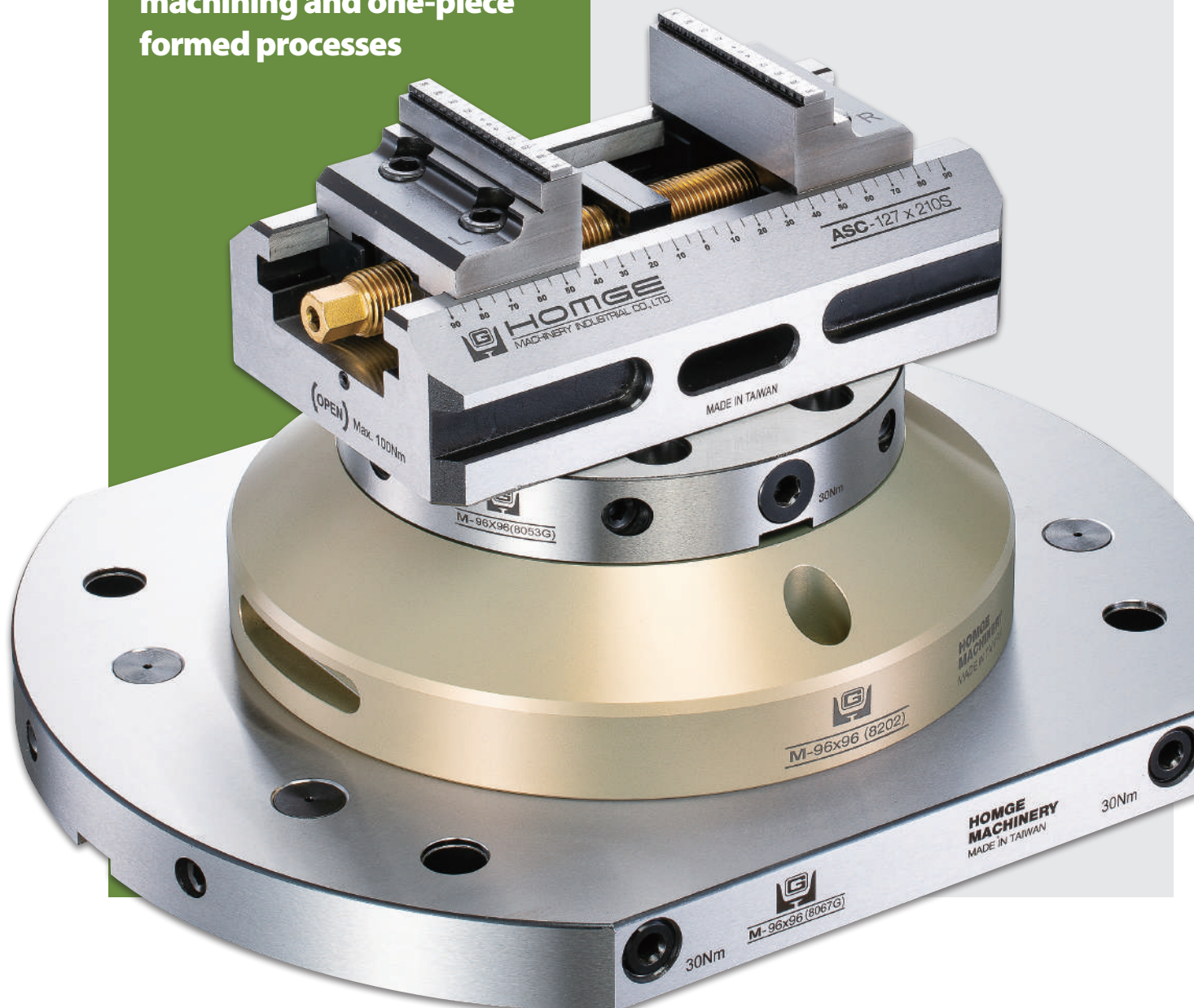

Round Aluminum Riser

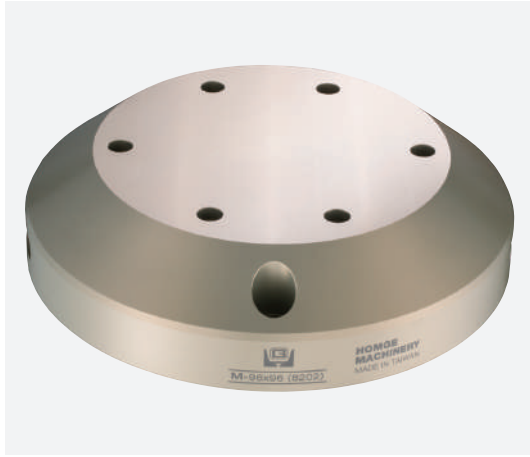

M-96x96 (8202)

Size $\text{Ø}246 \times 60$ mm

Pull Stud No. M-96x96PS

Mounting Holes as the drawing shown

Weight (kg) 7

Material Aluminum

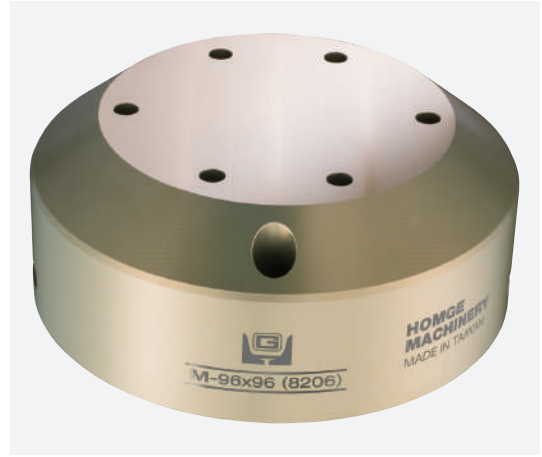

M-96x96 (8206)

Size $\text{Ø}246 \times 100$ mm

Pull Stud No. M-96x96PS

Mounting Holes as the drawing shown

Weight (kg) 12

Material Aluminum

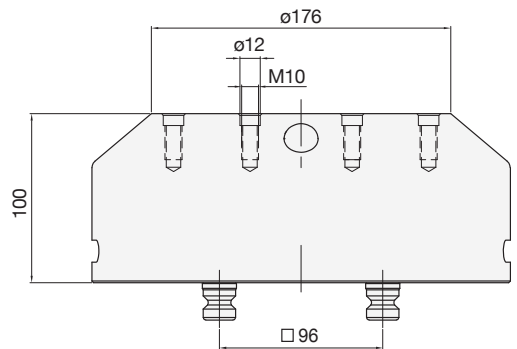
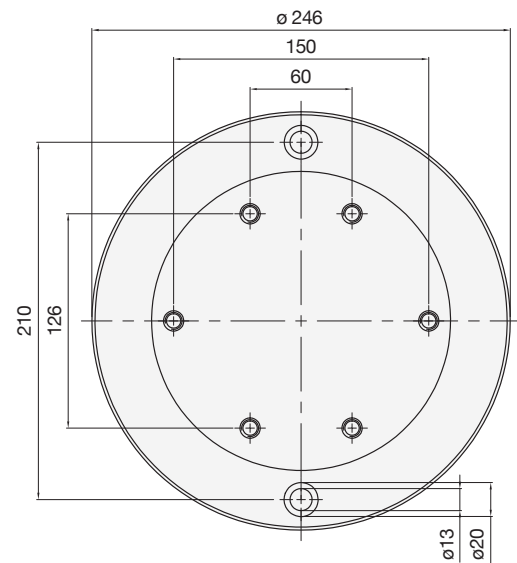
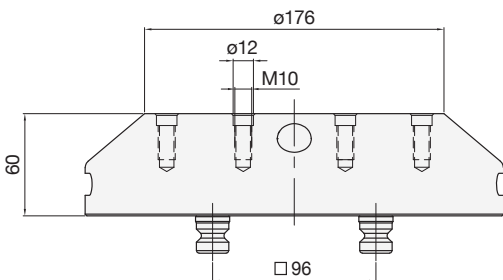
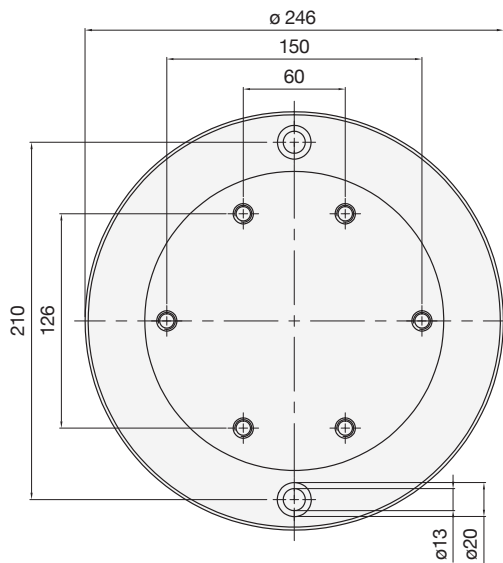

Rectangular Riser

(Height: 60 mm)



M-52x52 (3131G)

Size 150x116x60 mm

Pull Stud No. M-52x52PS / M-96x96PS

Mounting Holes -

Weight (kg) 7.9



M-96x96 (8222G)

Size 192x156x60 mm

Pull Stud No. M-96x96PS

Mounting Holes -

Weight (kg) 13.5

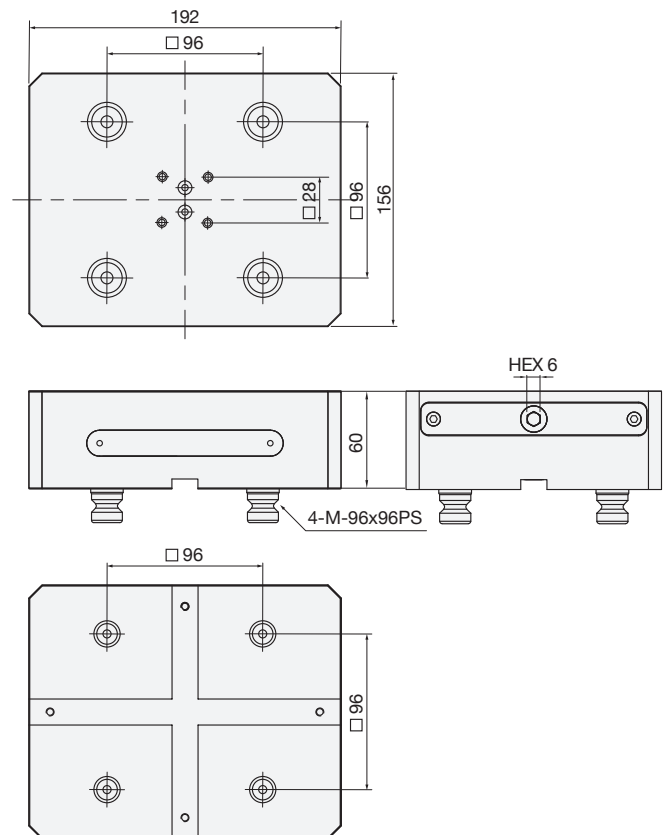
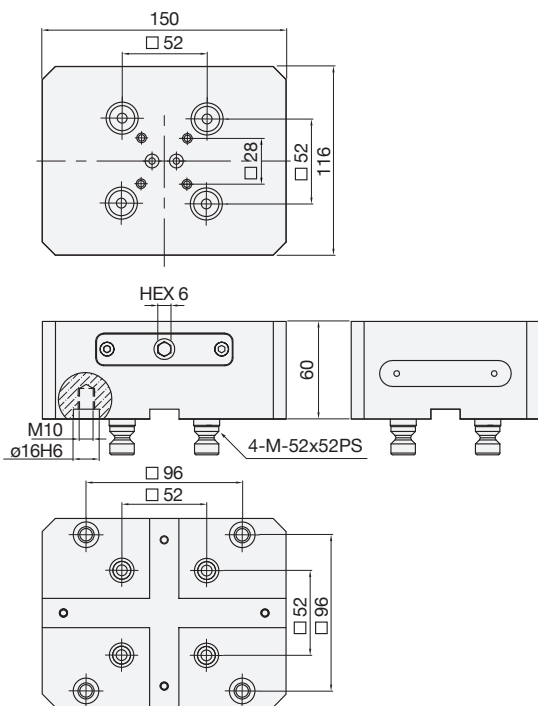

Rectangular Riser

(Height: 100 mm)



M-52x52 (3133G)

Size 150x116x100 mm

Pull Stud No. M-52x52PS / M-96x96PS

Mounting Holes -

Weight (kg) 12.9



M-96x96 (8226G)

Size 192x156x100 mm

Pull Stud No. M-96x96PS

Mounting Holes -

Weight (kg) 22.5

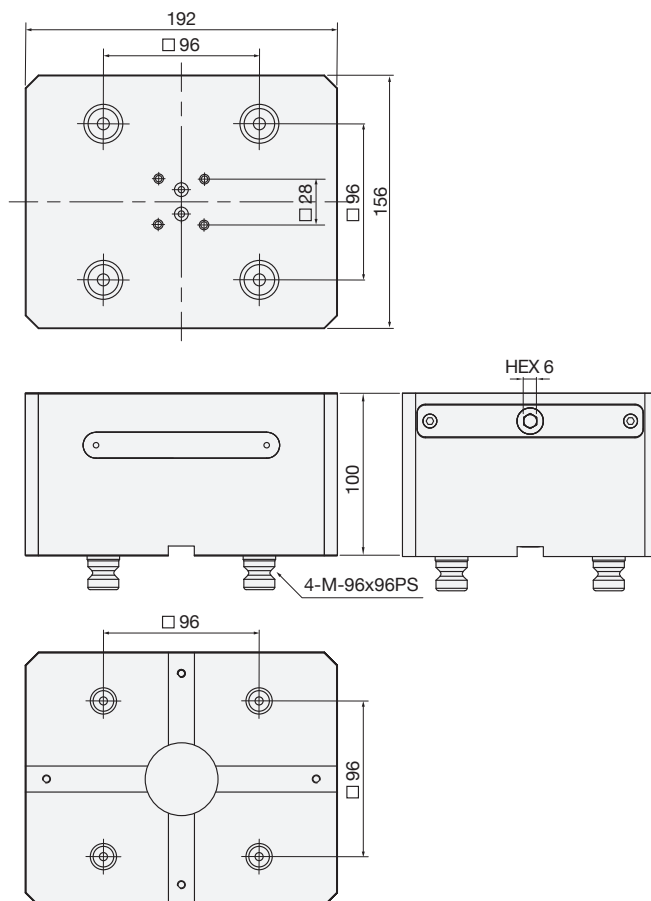
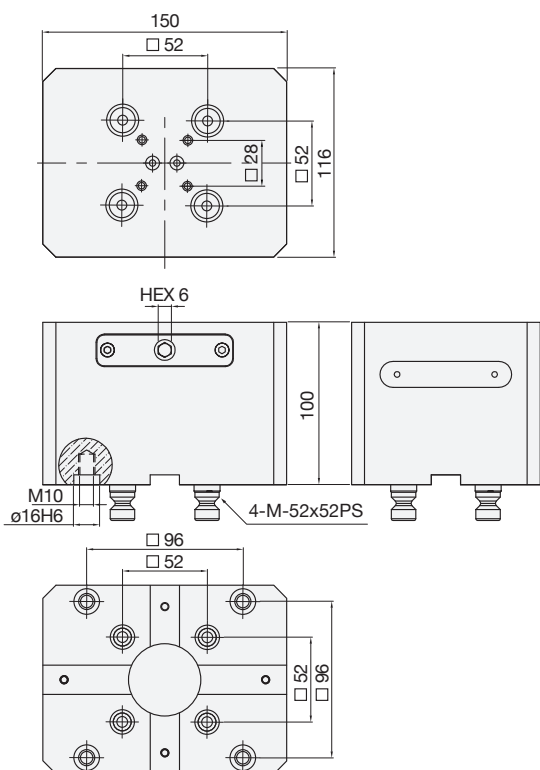

Multi Plate

Multi plates provide more positioning points, allowing users to effectively use the space of machine tables; whether it is fixing a single large workpiece or multiple small parts, the fixture positioning is fast and accurate



Multi Plate / 2-Fold Grid Plate

RECTANGULAR without Mounting Bores



M-52x52 (7062G)

Size	208x104x30 mm
Pull Stud No.	M-52x52PS
Mounting Holes	186x82 mm
Weight (kg)	4.6
Standard Accessories	Cover Plug M-52x52CPS x 8 pcs Cover Plug with Hook M-52x52H x 2 pcs Cover Plug Remover x 1 pc

ROUND with Mounting Bores for 100mm T-Slot distance



M-96x96 (8062G)

Size	384x192x30 mm
Pull Stud No.	M-96x96PS
Mounting Holes	-
Weight (kg)	14
Standard Accessories	Cover Plug M-96x96CPS x 8 pcs Cover Plug with Hook M-96x96H x 2 pcs Cover Plug Remover x 1 pc

M-96x96 (8067G)

Size	Ø384x316x30 mm
Pull Stud No.	M-96x96PS
Mounting Holes	as the drawing shown
Weight (kg)	21.2
Standard Accessories	Cover Plug M-96x96CPS x 8 pcs Cover Plug with Hook M-96x96H x 2 pcs Cover Plug Remover x 1 pc

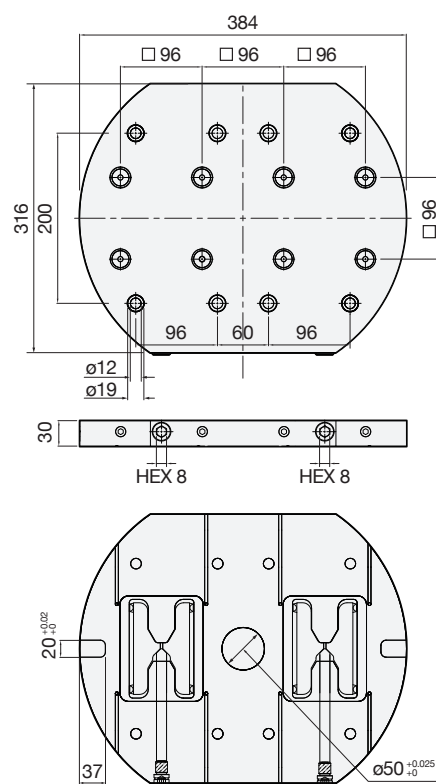
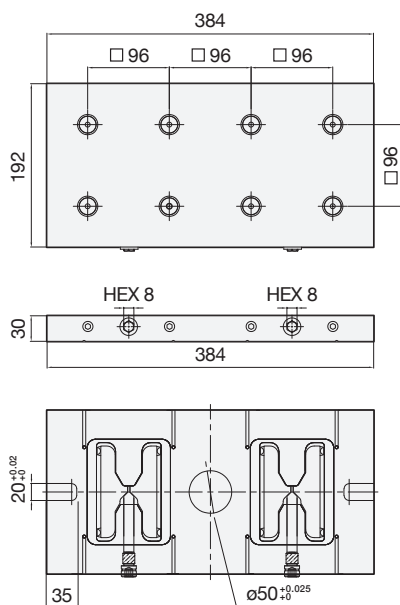
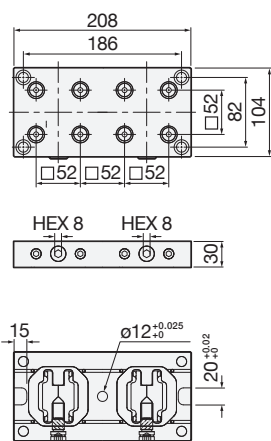

Multi Plate / 4-Fold Grid Plate

M-52x52 without Mounting Bores



M-52x52 (8026G)

Size 208x208x30 mm

Pull Stud No. M-52x52PS

Mounting Holes -

Weight (kg) 11

Standard Accessories Cover Plug M-52x52CPS x 16 pcs
Cover Plug with Hook
M-52x52H x 2 pcs
Cover Plug Remover x 1 pc

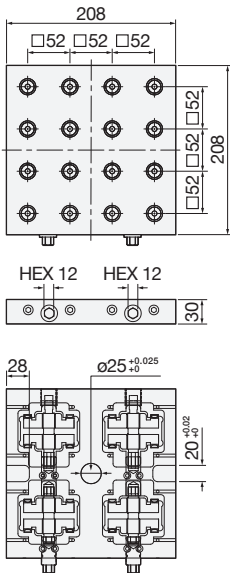

M-96x96 without Mounting Bores



M-96x96 (8066G)

Size 384x384x30 mm

Pull Stud No. M-96x96PS

Mounting Holes -

Weight (kg) 32

Standard Accessories Cover Plug M-96x96CPS x 16 pcs
Cover Plug with Hook
M-96x96H x 2 pcs
Cover Plug Remover x 1 pc

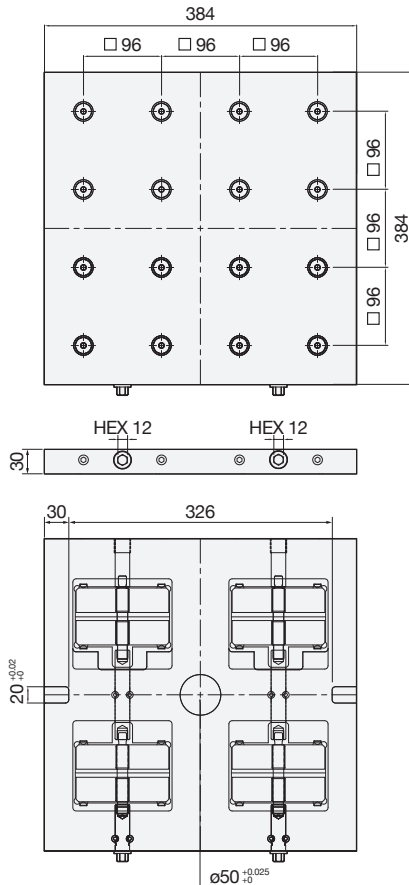

with Mounting Bores

M-96x96 (8066G-M)

Size 384x384x30 mm

Pull Stud No. M-96x96PS

Mounting Holes as the drawing shown

Weight (kg) 31.5

Standard Accessories Cover Plug M-96x96CPS x 16 pcs
Cover Plug with Hook
M-96x96H x 2 pcs
Cover Plug Remover x 1 pc

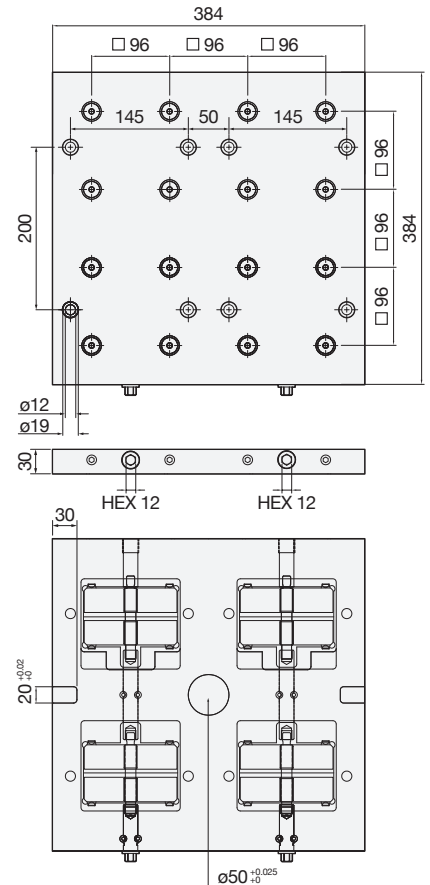

Side-Mounted Plate

M-96x96

1-Fold



M-96x96 (8086G)

Size 192x192x30 mm

Pull Stud No. M-96x96PS

Mounting Holes -

Weight (kg) 7.8

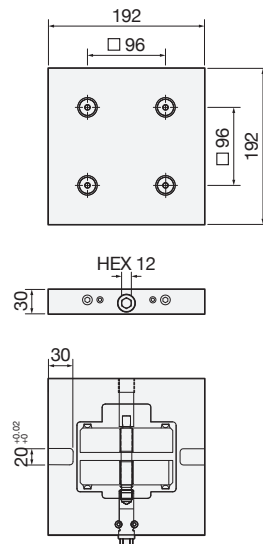

2-Fold



M-96x96 (8088G)

Size 384x192x30 mm

Pull Stud No. M-96x96PS

Mounting Holes -

Weight (kg) 15.7

Standard Accessories
 Cover Plug M-96x96CPS x 8 pcs
 Cover Plug with Hook M-96x96H x 2 pcs
 Cover Plug Remover x 1 pc

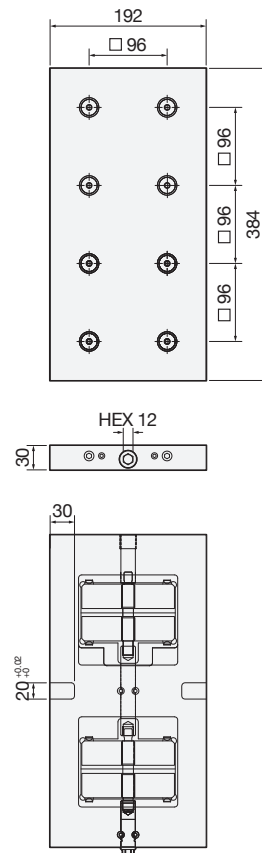

Clamping Bridge

Single Clamping Bridge for 4-Axis



M-96x96 (8072G)

Size 576x192x30 mm

Pull Stud No. M-96x96PS

Mounting Holes -

Weight (kg) 24.3

Standard Accessories Cover Plug M-96x96CPS x 12 pcs
Cover Plug with Hook M-96x96H x 2 pcs
Cover Plug Remover x 1 pc

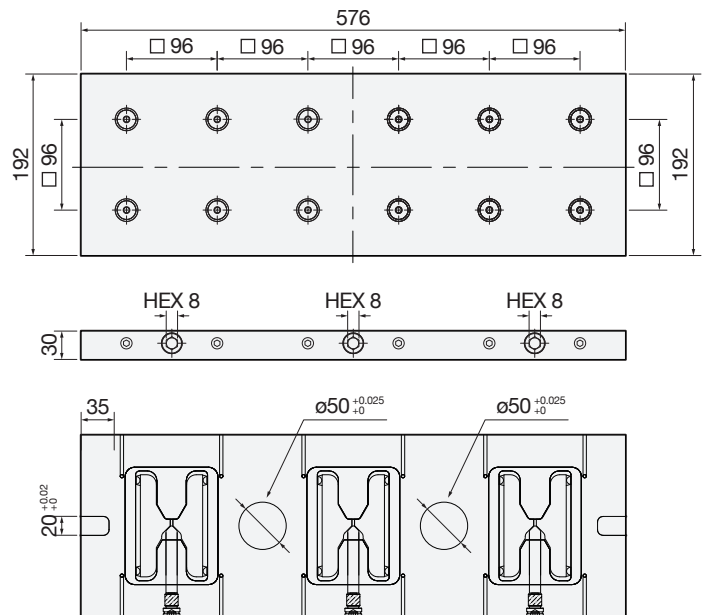

Clamping Bridge

Twin Clamping Bridge for 4-Axis

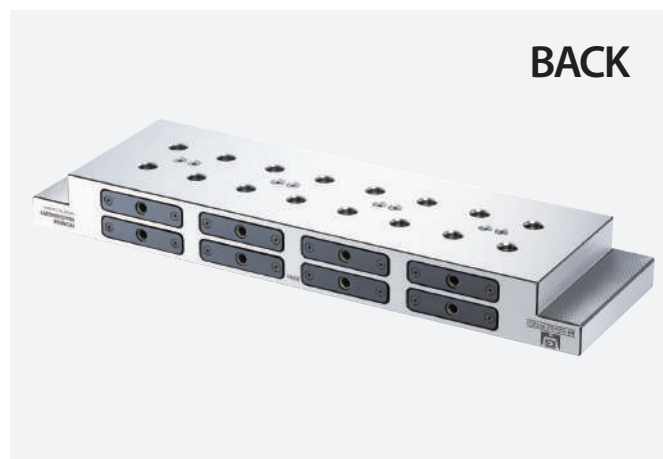

M-52x52 (8022G)

Size	550x156x60 mm
Pull Stud No.	M-52x52PS
Mounting Holes	-
Weight (kg)	34.2
Standard Accessories	Cover Plug M-52x52CPS x 32 pcs Cover Plug with Hook M-52x52H x 2 pcs Cover Plug Remover x 1 pc

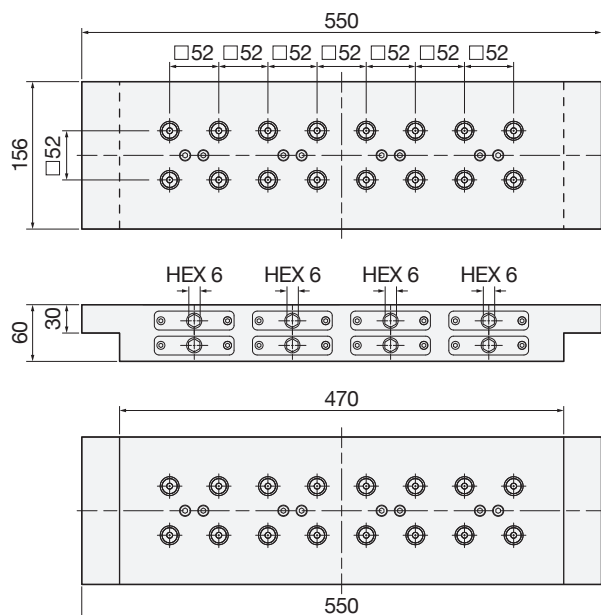

Tombstone

Advancements in Machining Centers Efficiency

The 3-sided or 4-sided Tombstone effectively enhances changeout efficiency in machining centers, particularly with smaller 5-axis machines. This innovation overcomes conventional clamping setup restrictions, enabling the execution of complex tasks even on compact machines.



Tombstone

3-Faced Tombstone

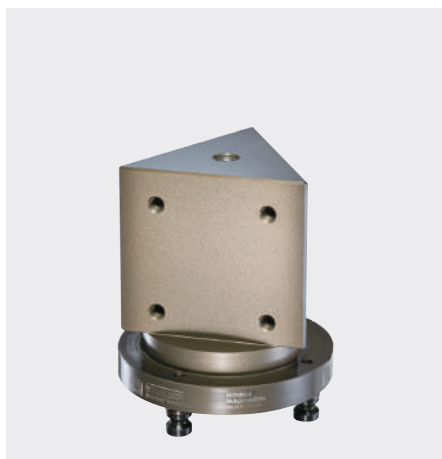

M-52x52 (9313)

Size	Ø160x167 mm
Pull Stud No.	M-52x52PS/ M-96x96PS
Mounting Holes	-
Weight (kg)	4.5
Compatible with	Grid Plate M-52x52 (8011G) x 3 pcs



M-52x52 (9333)

Size	192x192x260 mm
Pull Stud No.	M-52x52PS/ M-96x96PS
Mounting Holes	-
Weight (kg)	15.2
Compatible with	Grid Plate M-52x52 (8011G) x 6 pcs

4-Faced Tombstone



M-52x52 (9433)

Size	192x192x260 mm
Pull Stud No.	M-52x52PS/ M-96x96PS
Mounting Holes	-
Weight (kg)	12.5
Compatible with	Grid Plate M-52x52 (8011G) x 8 pcs

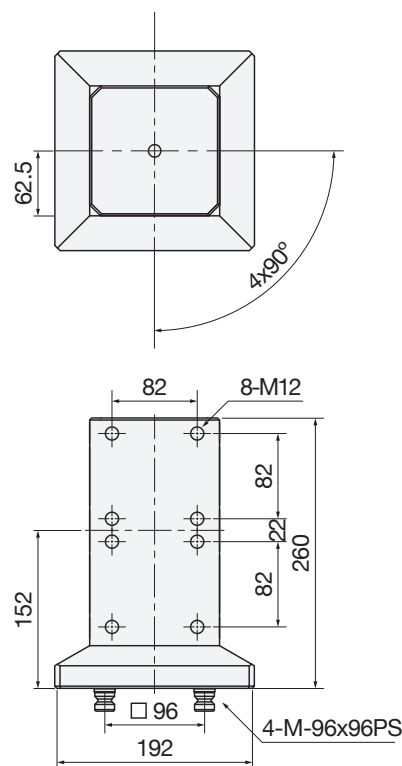
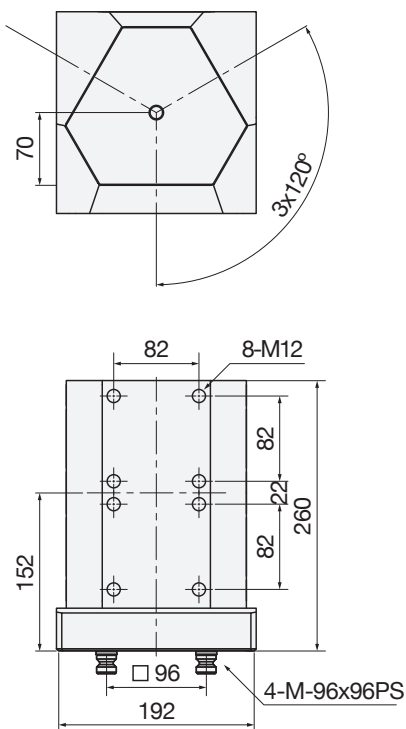
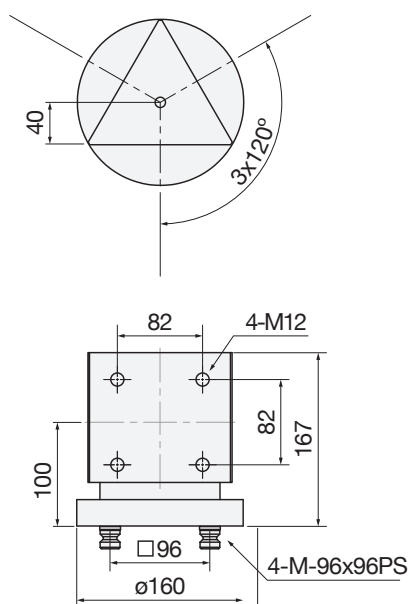

3-Faced Pyramid



M-52x52 (9314)

Size	Ø250x105 mm
Pull Stud No.	M-52x52PS/ M-96x96PS
Mounting Holes	—
Weight (kg)	12.7
Compatible with	Round Plate M-52x52 (8004G) x 3 pcs

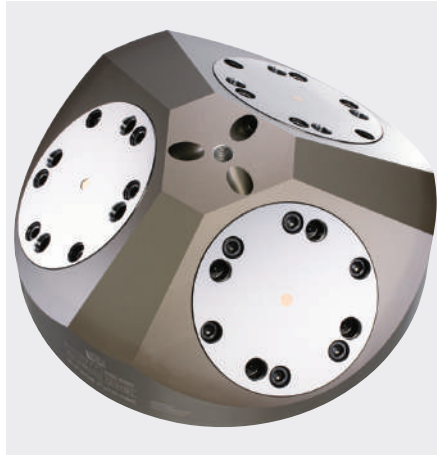
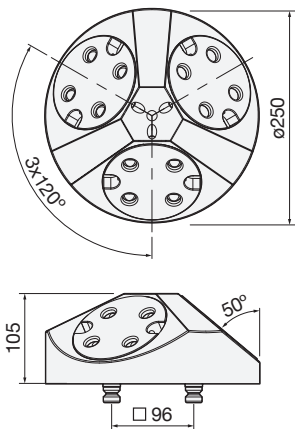

M-96x96 (9319)

Size	Ø400x150 mm
Pull Stud No.	M-96x96PS
Mounting Holes	—
Weight (kg)	44
Compatible with	Grid Plate M-96x96 (80522G) x 3 pcs

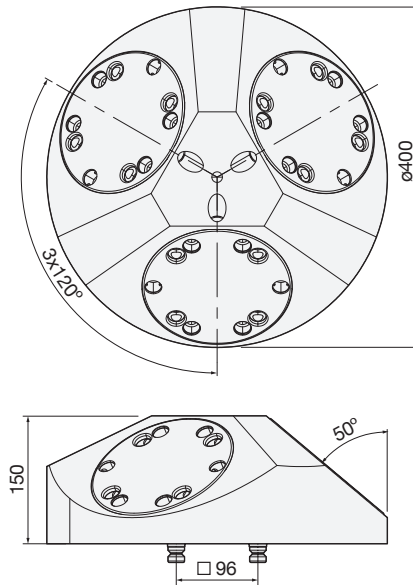

Combo Plate / Raiser



M-52/96 (8287G)

Size	192x192x30 mm
Pull Stud No.	M-52x52PS/ M-96x96PS
Mounting Holes	—
Weight (kg)	9.4

M-52/96 (8288G)

Size	Ø246x30 mm
Pull Stud No.	M-52x52PS/ M-96x96PS
Mounting Holes	—
Weight (kg)	10.6

M-52/96 (8282G)

Size	192x156x60 mm
Pull Stud No.	M-52x52PS/ M-96x96PS
Mounting Holes	—
Weight (kg)	12.5

M-52/96 (82822G)

Size	192x156x100 mm
Pull Stud No.	M-52x52PS/ M-96x96PS
Mounting Holes	—
Weight (kg)	18.1

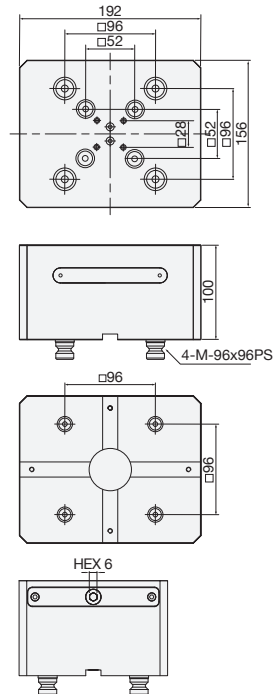
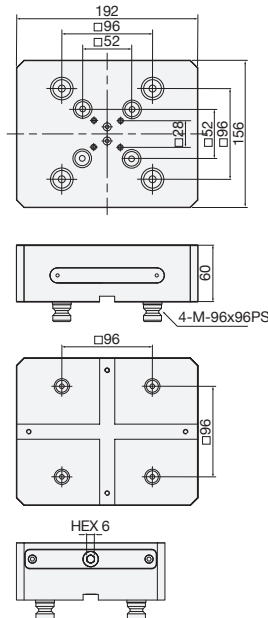
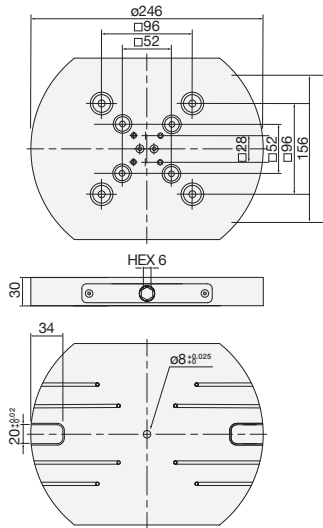
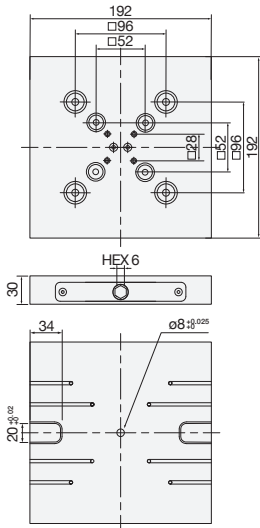

Top Clamping

Collect Chuck

Model: M-52x52 (ER32)C

- Size: Ø98x86 mm
- Weight: 2.0 kg

Model: M-52x52 (ER50)C

- Size: Ø98x100 mm
- Weight: 3.1 kg



Round Bar Fixture

Model: M-52x52 (ER32)

- Size: 75x75x79 mm
- Weight: 1.5 kg

Model: M-52x52 (ER40)

- Size: 75x75x81 mm
- Weight: 1.7 kg



Model: M-96x96 (ER32)

- Size: 125x125x85 mm
- Weight: 3.7 kg

Model: M-96x96 (ER40)

- Size: 125x125x87 mm
- Weight: 3.9 kg

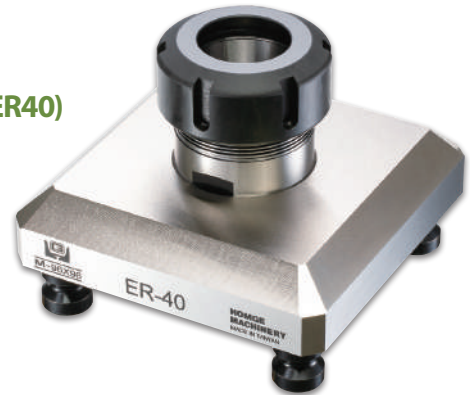

Dovetail Fixture

Model: M-52x52 (D16)

- Size: 75x75x55 mm
- Weight: 1.1 kg



Optional Accessories

for Zero Point Quick Change Devices

Pull Studs

Can be adopted onto vises or workpieces to use together with any Quick Change Device.

Model: M-52x52PS

- 4 pcs / set
- Weight: 0.16 kg / set



Model: M-96x96PS

- 4 pcs / set
- Weight: 0.28 kg / set



Spacer Studs

Improve the machining accessibility of edges or angles by making a through space between workpieces and Quick Change Devices.

Model: M-52x52SS

- 4 pcs / set
- Weight: 0.27 kg / set



Model: M-96x96SS

- 4 pcs / set
- Weight: 0.4 kg / set



Cover Plugs - Plastic

Model: M-52x52CPP

- 4 pcs / set
- Weight: 0.01 kg / set



Model: M-96x96CPP

- 4 pcs / set
- Weight: 0.02 kg / set



Cover Plugs - Steel

Model: M-52x52CPS

- 4 pcs / set
- Weight: 0.10 kg / set



Model: M-96x96CPS

- 4 pcs / set
- Weight: 0.16 kg / set



Cover Plug with hook

Model: M-52x52H

- 2 pcs / set
- Weight: 0.18 kg / set



Model: M-96x96H

- 2 pcs / set
- Weight: 0.32 kg / set



Cover Plug Remover

for M-52x52 and M-96x96

- 1 pc
- Weight: 0.11 kg



STAMPING UNIT

Model: ASC-153

54 ZERO POINT QUICK CHANGE DEVICES / STAMPING UNIT



The tooth profiles of each stamping unit

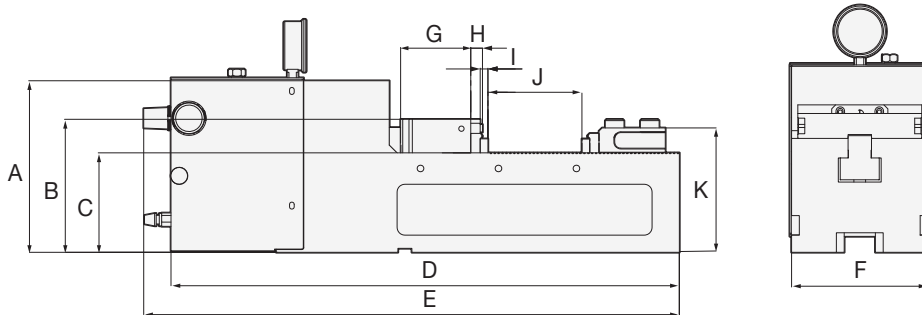

SPECIFICATIONS (Material: Material: FCD 60 ductile Iron. Hardness: HRC 50)

Unit: mm

Model	A	B	C	D	E	F	G	H	I
ASC-153	70	43	28	32	75	80	10	M6	102

Model	J	K	Max. Clamping Force	Safety Range	Weight(kg)
ASC-153	107	77	0-24000 kg	8 mm	117

SIMPLE, QUICK & ACCURATE

ASC-153 Stamping Unit can easily shape tooth profile on the workpiece, which allows precise positioning between the workpiece and the vise.

1 The body of the Stamping Unit is made of **Ductile Iron FCD 70** with patented **PNEUMATIC SYSTEM**. Required tooth profile is pre-stamped onto the workpiece with high pressure, so that the workpiece will be stably clamped by the corresponding tooth profile on five-axis vise.

2 The stamping force is between **0~24 tons**, which is suitable for stamping tooth profile on both soft and hard materials. The black knob is **pressure regulator**, used to set pneumatic force according to processing conditions.

3 The serrated jaws of stamping unit are made of **Tool Steel**, heat-treated to achieve hardness above **HRC55** and marked with scales to facilitate accurate positioning. It is recommended that the hardness of workpiece should not exceed HRC35.

4 The effective stamping stroke of the moveable jaw is **10mm**: during the initialization phase, please adjust the jaw spacing according to the width of the workpiece and make sure to reserve **3~5mm** as a margin for smooth loading/unloading. Meanwhile, please refer to the scale on the jaws to set the datum point.

5 Pre-stamping is beneficial to both hard and soft workpieces. The former can effectively reduce wear and tear caused by workpiece on the serrated jaws; the latter can avoid workpiece deformation caused by excessive pressure for stable clamping.

6 By engaging the teeth profile of both the workpiece and the vise, clamping accuracy can be fully guaranteed; therefore, it is ideal for multi-part processing and automatic processing.

7 Customized serrated jaws of the stamping unit are acceptable.

- Simple setting, Quick pre-stamping, which can greatly improve the reliability of five-axis processing.



FAST ACTUATION SYSTEM

HANS TREIBER

Gutenbergstrasse 19, 24558 Henstedt-Ulzburg | 04193-77943
mail@hanstreiber.de | shop.hanstreiber.de | fraeser-shop.de

56

ZERO POINT QUICK CHANGE DEVICES / ACCESSORIES / FAST ACTUATION SYSTEM

workpieces can be clamped firmly by rotating the clamping lever 180 degrees from right to left



Model: M-52x52AS

- 1 set
- Weight: 0.49 kg / set

Model: M-96x96AS

- 1 set
- Weight: 0.63 kg / set